



懋莉工業股份有限公司  
MONY INDUSTRIAL CO.,LTD

[www.mony.com.tw](http://www.mony.com.tw)

📍 台南總公司 / Headquarter  
71047 台南市永康區正南三路75號  
75, Jheng Nan 3rd Road, Yung Kang Dist.,  
Tainan City 71047, Taiwan

☎ TEL : +886.6.2543888

📠 FAX : +886.6.2435160

✉ Mail : [info@mony.com.tw](mailto:info@mony.com.tw)



KNOBBS

# KNOBBS CATALOG

Turning knobs / Pointer knobs / Band knobs /  
Slide control knobs / Control knobs /  
Machined aluminum & Shell knobs /  
DIY control knobs & Accessories /  
Double-shot knobs / Feet pad /  
Fasten knobs / Push knobs /



懋莉工業股份有限公司  
MONY INDUSTRIAL CO.,LTD



## ABOUT US

懋莉工業股份有限公司於1977年成立，是台灣高品質塑膠製造業的領導者之一，專精於多色射出技術及專用模具設計。

公司對塑膠產品的前製與後製作業，皆擁有完整且先進的製程設備與技術經驗，例如：產品自動化組裝設備、全自動噴漆塗裝設備、PVD真空鍍膜機、移印、曲印機及雷射雕刻機。主要產品包括家電零件、汽車零件、電子工業相關產品、把手工具、各式按鍵及旋鈕。

為因應全球市場需求，懋莉工業遵循嚴格的品質管理制度，獲得ISO14001與IATF16949品質認證，不停的提升經營與產品開發視野，並於2017年榮獲國家磐石獎肯定，讓懋莉工業，邁向一個新的里程碑。

MONY INDUSTRIAL CO., LTD, established in 1977, is a leading manufacturer of high quality plastic components in Taiwan, specialized in multi-injection molding and mold design development.

Mony owns the rich experiences and complete processes, such as part assembly, pad printing, screen printing, automatic painting, PVD vacuum coating and laser etching. Our main products are decorative plastic components for the household appliances, electronic products, automobiles, hand tools, keypads and knobs.

Through strict quality control system, Mony acquired ISO14001 & IATF16949. Certified Mony was proud to win recognition of National Award of Outstanding SMEs in 2017, a moreover remarkable milestone to stand in the competitive markrts.



Certified  
IATF16949



## OEM SERVICE

### 塑膠射出機 / Injection Molding

#### ● 單色塑膠射出機 / Single Shot Injection Machine

先進微電腦控制的自動化塑膠射出機設備，適合生產精密製品。機台大小(鎖模力)從27噸到260噸，每台塑膠射出機都具有機械手臂，自動抓取產品與料頭，並配有小口徑料管，適合生產小且精密的產品。

Mony's advanced automatic PLC controlled plastic injection molding equipment is suitable for producing precision products. The clamping force of our Injection molding machines are from 60 tons to 260 tons, and each plastic injection machine is equipped a robot arm to capture plastic injection parts automatically. Our machines with a small diameter of injection molding screws are also suitable for producing small and precise products.

#### ● 雙色塑膠射出機 / Two Shots Injection Machine

擁有微電腦數位控制系統，可自動儲存模具成型條件，並自動偵錯監視，迅速穩定的生產，降低不良率。機台大小(鎖模力)從130噸到350噸，每台塑膠射出機都具備兩支以上的機械手臂和自動輸送帶，可進行全自動化的生產。

Mony's advanced PLC controlled plastic injection molding equipment is able to store plastic injection molding parameters automatically. This machine can detect and monitor error features, contribute a lower defect rate with a rapid and stable production process. The clamping force of our Injection molding machines is from 120 tons to 350 tons. Each plastic injection machine has more than two robotic arms and automatic conveyor belts, which can be fully automated production.

### 機械設備 / Facilities

#### 塑膠射出機台 / Plastic injection molding machines

單色射出機台 / Single shot machine (27 Ton~260 Ton) 17 台 / unit

雙色射出機台 / Two shots machine (130 Ton~350 Ton) 19 台 / unit

### 模具相關設備 / Mold Shop

#### ● CNC切削中心機 / CNC Rotary Cutting Machine

全自動化模具加工設備，可讓模具自動進行銑切、鑽孔、搪孔、絞孔、攻絲與切削輪廓等加工作業。

Mony's tooling plant is equipped with CNC machines providing fully automated processing e.g., milling, drilling, boring, reaming, tapping, and cutting contour processing operations.

#### ● CNC放電機 / CNC EDM Machine

是XYZ三軸數控或更多軸數控的放電機。CNC放電機具有自動靠模、自動尋心、自動編程、G碼編程、三軸聯動放電等諸多功能。

Mony's tooling plant is equipped with XYZ three-axis CNC EDM machines which provide multiple functions, such as automatic mold making, automatic center finding, automatic programming, G code programming, three-axis linkage discharge, etc.



# OEM SERVICE

## 模具相關設備 / Mold Shop

### ● 研磨機 / Grinding Machine

擁有平面研磨機與成型研磨機，可做平面、角度、圓形等物品尺寸加工。Mony's tooling plant is equipped with a surface grinder and a shape grinder, which can process flat, different angle, and round shapes.



## 噴漆設備 / Painting System

### ● 自動噴漆設備 / Automatic Painting System

往復式與循環式兩種噴塗設備，自動進行噴塗製程。可適用於各種塑膠零件的噴塗，品質穩定，不良率低，可連續生產，效率高。目前使用在各類家電零件、汽車零件等產品上。

Mony's painting plant is equipped with single gun and double gun spraying facilities. Items can be automatically sprayed by automatic robot after feeding raw plastic items. It is suitable for spraying on various plastic parts and can be continuous production with a stable quality, a low defect rate, and high efficiency. It is currently used on various home appliance parts, automobile parts and etc.



### ● 自動化機器人 / Automatic Robot

自動化機器人可自動夾料、送料及取料，可大幅度降低噴塗的雜質不良率。The automatic robot can pickup, feed, and reclaim trays of raw plastic item automatically, which can greatly reduce the defect rate of impurities in spraying.



### ● 真空鍍膜機 / PVD Vacuum Coating Machine

懋莉工業的新製程，利用電阻式加熱升溫使達到汽化與材料蒸發，並將材料均勻地附著在產品表面的一種鍍膜技術，可運用在多種塑膠材料上。

PVD is Mony's new manufacturing process, which is a coating technology by heating the electron beams to vaporize and evaporate materials, and the materials will attach evenly to the products' surfaces. This technology can be applied to a variety of plastic materials.



## 自動移印/網印機 / Auto Pad Printing

由微電腦控制，可針對塑膠、金屬等不同材質，進行旋鈕表面或是凹凸不平面產品的客製化圖樣印刷，不良率低且生產速度快。

Mony's PLC controlled printing facilities can print customized ring patterns on the surface of knobs or uneven products for different materials, such as plastic and metal.



## 雷射雕刻機 / Laser Etching

● 光纖式雷射雕刻機 / Lamp Pumped Nd : YAG Laser Marking  
適用材質有：金屬材料、烤漆表面、塑膠材料等。目前懋莉工業可將其應用在家電零件、塑膠噴塗後雕刻等產品上，不僅生產速度快，不良率也相當低。

Applicable materials for laser engravings are: metal materials, painted surfaces, plastic materials, etc. Currently, Mony Industry is applying this technique to home appliance parts, engraving plastic products after spraying, with a high production rate and a very low defect rate.

# OEM SERVICE

## 機械設備 / Facilities

### 組裝 / Assembly

複合式鑲合機 / multifunction bonding machine	6 台 / unit
複合式熱燙機 / Hot foil stamping machine	6 台 / unit
平面燙金機 / Direct action plane hot stamping machine	6 台 / unit
自動彈片機 / Auto spring insertion machine	4 台 / unit
壓邊機 / Edge pressing machine	1 台 / unit
彈圈組立機 / Spring assembly machine	1 台 / unit
超音波機 / Ultrasonic Machine	2 台 / unit
雙軸自動鎖螺絲機 / Auto dual axle screwing machine	1 台 / unit
雙壓式鑲合機 / double press bonding machine	1 台 / unit



### 印刷 / Printing

移印機 / Pad printing machine	13 台 / unit
網印機 / Screen printing machine	14 台 / unit



### 噴漆 / Spray Painting

平面往赴式噴漆機 - 雙槍 / Automatic spray painting - dual head	1 台 / unit
平面往赴式噴漆機 - 單槍 / Automatic spray painting - single head	1 台 / unit
循環式噴漆機 / Automatic spraying - spindle	1 台 / unit
光纖雷射機 / Laser etching	1 台 / unit
曲面燙金機 / Cylindrical hot stamping machine	3 台 / unit
真空電鍍爐 / Vacuum plating	1 台 / unit



## 檢驗測量設備 / Quality Measurement Instruments

### ● 三次元座標量床 / Coordinate Measuring Machine

以高性能的三次元量床取代人工量測，可執行全尺寸量測、3D 曲面量測，精準的再現性測量。

A high-performance of three-dimensional measuring bed has been replaced the manual measuring, and it can perform full-scale measurement and 3D curved surface measurement with a great accuracy and repeatability.



### ● 背光測色機 / Spectro Radiometer

先進的光學量測儀器，該儀器是檢測汽車儀表板上圖形的顏色，是針對透明的物件檢測，當有背部光源 (Backlit) 的情況下，可模擬出日間和夜間的明暗度和彩度值，來進行分析。



# OEM SERVICE

SpectroRadiometer is an advanced optical measuring instrument. This instrument is used to detect the color of the graphic on the dashboard of cars. It is for the detection of transparent objects. When there is a backlit, it can simulate the lightness, darkness and chroma of the day and night for further analysis.

● 測色機 / Spectrophotometer

此光學量測設備，可檢測非透明產品的顏色，分析產品與樣品的亮度、顏色差異等，使產品品質更加穩定。

This optical measuring device can detect the color of non-transparent products and analyze the brightness and the color differences between products and samples in order to increase the stability of the product quality.

● 非接觸式影像量測系統 / Tool Scope System

高倍率影像量測，可精準量測和計算產品上各個平面的細部尺寸。

With a high magnification image measurement, the system can accurately measure and calculate the detail size of each surface on the products.

● CCD影像感應器 / CCD Vision System

可檢測圖形的顏色明暗度及輪廓完整性。

This system can detect the brightness and contour of graphics..

## 機械設備 / Facilities

### 檢測用設備 / Inspection And Testing

影像量測儀 (2.5D) / 2.5D - Image Processing Measuring Instrument	1 台 / unit
影像量測儀 (2.5D) / 2.5D - Image Processing Measuring Instrument	1 台 / unit
CMM (三次元) / Coordinate Measuring Machine	1 台 / unit
膜厚計 (片) (0~1500um) / Coating Thickness Tester (0~1500um)	1 台 / unit
廣柏分光測色儀 / Spectrophotometer	1 台 / unit
背光測色儀 PR-705/715 / Spectro Radiometer	1 台 / unit
光澤度計 60度 / Gloss Meter 60	2 台 / unit
表面粗度計(±160um/0.6mm/s) / Surface Roughness Tester	1 台 / unit

## 表面處理 / Surface Decoration

水電鍍、真空電鍍、髮絲紋、噴砂、噴漆、雷射雕刻 & 多色印刷

We are capable of providing variety of surface decorations : water plating, PVD, hairline treatment, sandblasting, laser engraving and multi-color printing.



# CONTENT

07 轉鈕  
Turning knobs

17 全鋁及鋁殼旋鈕  
Machined aluminum & Shell knobs

27 指示旋鈕  
Pointer knobs

33 滑鈕  
Slide control knobs

35 握把旋鈕  
Band knobs

37 控制旋鈕  
Control knobs

44 機械旋鈕  
Fasten knobs

45 按鍵鈕  
Push knobs

46 雙色旋鈕  
Double-shot knobs

49 DIY旋鈕及配件  
DIY control knobs & Accessories

51 腳墊  
Feet pad

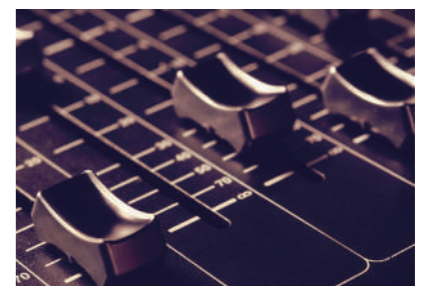



轉鈕  
全鋁及鋁殼旋鈕  
指示旋鈕  
滑鈕  
握把旋鈕  
控制旋鈕  
機械旋鈕  
按鍵旋鈕  
雙色旋鈕  
DIY旋鈕及配件  
腳墊

Description

- Material : black phenolic
- With spun aluminum top inlay
- With line indicator on top
- With lateral screw fixing

- 材質：黑色電木
- 鋁質銘板
- 上銘板加指示線
- 鎖螺絲

PART NO.	D	d1	d2	H	h1	h2
41001-1	20	6	12	16	3.5	13
41001-2	24	6	15.5	16	3.5	13

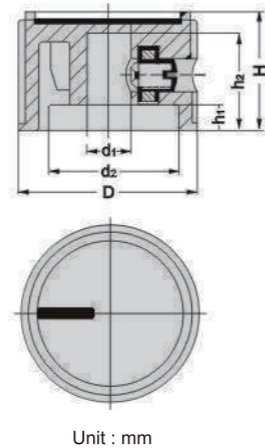

Unit : mm

Description

- Material : black phenolic or black ABS
- With aluminum capped cover
- Black dot indicator on top
- With lateral screw fixing

- 材質：黑色電木或ABS塑膠
- 鋁質上蓋加黑色指示點
- 鎖螺絲

PART NO.	D	d	H	h
41002-1	21	6	10	8
41002-2	24	6	12	10

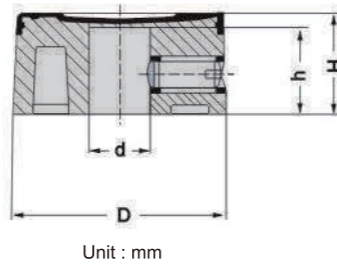

Unit : mm

Description

- Material : black phenolic
- Straight knurled with aluminum cap
- With indicator line on top
- With lateral screw fixing

- 材質：黑色電木
- 直齒狀鋁質上蓋加指示線
- 鎖螺絲

PART NO.	D	d1	d2	H	h1	h2
41003-1	14	4	11.4	14	2	12
41003-2	18.2	6	15	14.1	2	12.3

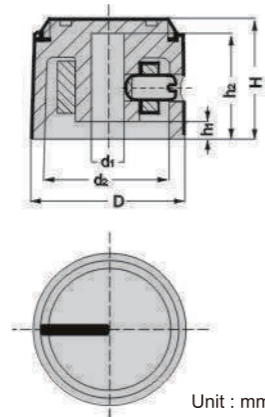

Unit : mm

Description

- Material : Phenolic
- With brass insert
- Ribbed body, matte finish with white indicator on top

- 材質：電木
- 鎖螺絲
- 埋銅
- 霧面，加白色指示點

PART NO.	A	B	C	D	E	F
41004-1	15.4	11.2	9.4	3.1	8.4	14.8
41004-2	20.6	15.6	11.9	2.8	8.1	16.2
41004-3	24.2	18.1	14	1.6	10.2	20
41004-4	35.6	27.1	23	2.3	7.4	18.3

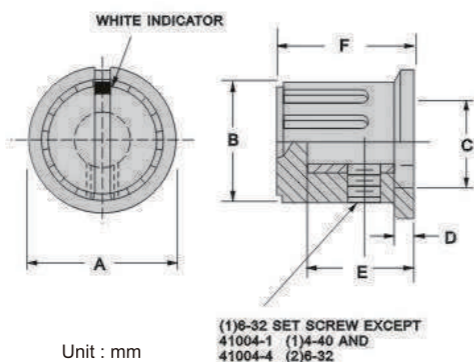

Unit : mm



(1)6-32 SET SCREW EXCEPT 41004-1 (1)4-40 AND 41004-4 (2)6-32

Description

- Material : ABS plastic insert
- Spun aluminum cap and ring assembly
- With lateral screw fixing

- 材質：ABS塑膠
- 鋁質上蓋加外環組合
- 鎖螺絲

PART NO.	D	d	H	h
41005-1	16	4	15	13
41005-2	16	6	15	13
41005-3	22.2	6	14.3	12.2
41005-4	22.2	6	17.5	16.4
41005-5	32	6	14	12

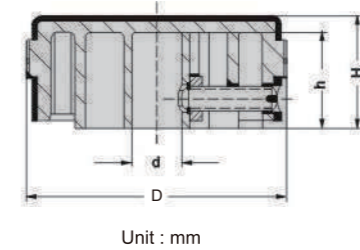

Unit : mm



Description

- Material : Phenolic
- With brass insert
- With No.6-32 set screw
- Straight knurl with dot indicator on skirt

- 材質：電木
- 鎖6-32號螺絲
- 上銘板，指示點
- 埋銅

PART NO.	A	B	C	D	E	F
41006-1	19.0	14.5	14.7	1.4	11.7	14
41006-2	25.4	18.7	18	2.03	12.7	15
41006-3	31.7	25.1	22.1	2.3	11.7	15

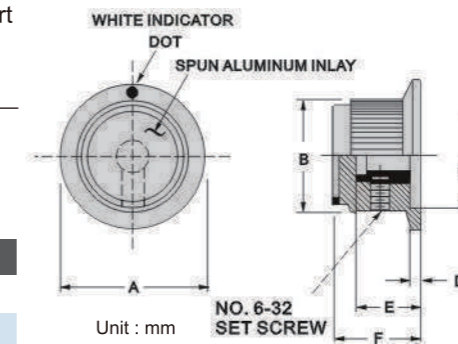

Unit : mm



Description

- Material : phenolic
- With two No.6-32 set screw
- Ribbed with line indicator on skirt

- 材質：電木
- 鎖2支6-32號螺絲
- 上銘板，指示線

PART NO.	A	B	C	D	E	F
41007-1	20	14.7	13.2	2.03	11.4	15
41007-2	20	14.7	13.7	2.03	11	15
41007-3	24.9	14.7	12	4.06	14.7	17.2
41007-4	24.9	14.7	12	4.06	14.7	17.2
41007-6	34.5	24.3	17.2	5.08	18.8	21.5
41007-7	19.8	14.7	12.1	3.4	14.9	17.1

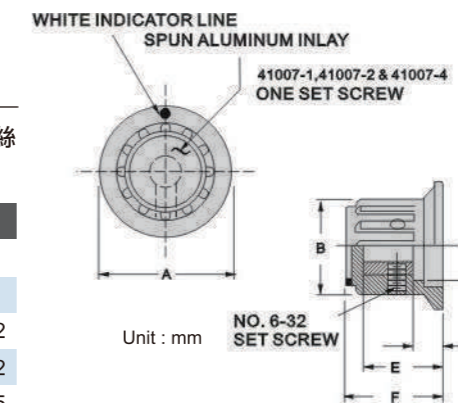

Unit : mm



Description

- Material : phenolic
- With brass insert
- With two No.6-32 set screw
- Ribbed with indicator line

- 材質：電木
- 鎖2支6-32號螺絲
- 埋銅
- 白色指示線

PART NO.	A	B	C	D	E	F
41008-1	21.8	20.6	18.3	2.03	10.4	14
41008-2	26.6	25.4	23.3	2.03	10.9	14

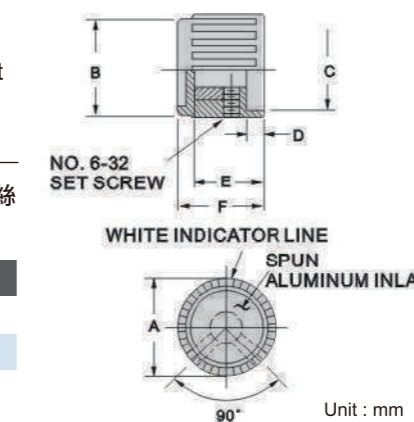

Unit : mm



**Description**

- Material : phenolic
- With No.6-32 set screw
- Fluted with skirt and indicator line

- 材質：電木
- 鎖6-32號螺絲
- 凹槽狀，鋁質上銘板與劃漆指示線

PART NO.	A	B	C	D	E	F
41009-1	19	15.7	11.6	2.29	9.4	11.9
41009-2	21.5	19	18	2.03	10.6	13.7
41009-3	25.4	22.6	22.1	2.03	11.9	14.4
41009-4	33	29.4	25.4	3.05	12.7	16
41009-5	37.6	34.3	31	3.05	13.9	17.5

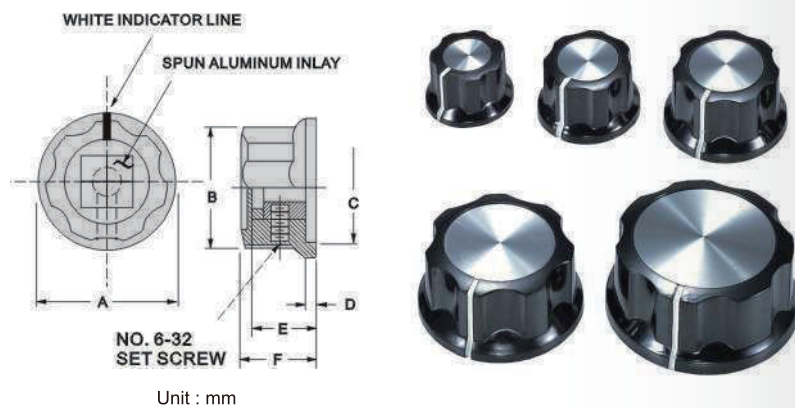

Unit : mm

**Description**

- Material : phenolic
- With No.6-32 set screw
- Ribbed with indicator line

- 材質：電木
- 鎖6-32號螺絲
- 劃漆指示線

PART NO.	A	B	C	D	E	F
41010-1	11	10.4	8.13	2.03	9.65	11.9
41010-2	14	12.7	11.1	1.42	10.03	13.2
41010-3	16.7	15.5	14	2.03	10.9	14
41010-4	18.8	17.8	15	2.03	11.4	14

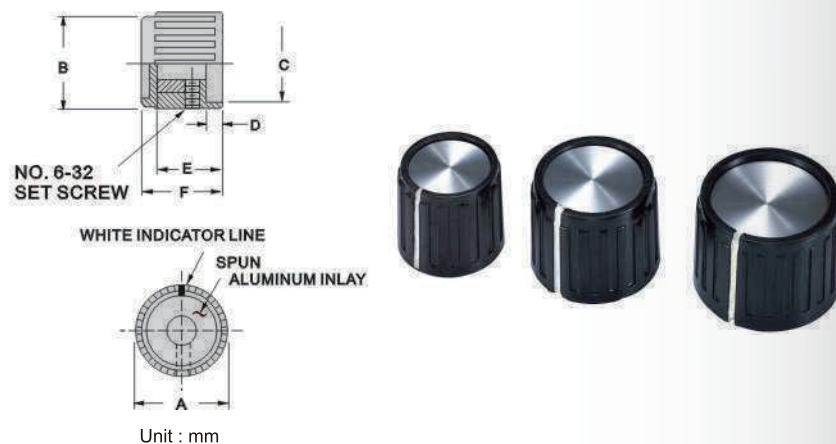

Unit : mm

**Description**

- Material : ABS
- Finish color : Matte black
- Top inlay options : plain, any colors / indicator line / indicator dot

- 材質：ABS塑膠
- 表面顏色：黑色霧面
- 上銘板可選擇素色或任何顏色，加指示線或指示點

PART NO.	A	B	HOLE
41012-1	13.2	16.26	6.4 DIA
41012-2	18.29	18.79	3.2 / 6.4 DIA
41012-3	23.37	21.84	3.2 / 6.4 DIA

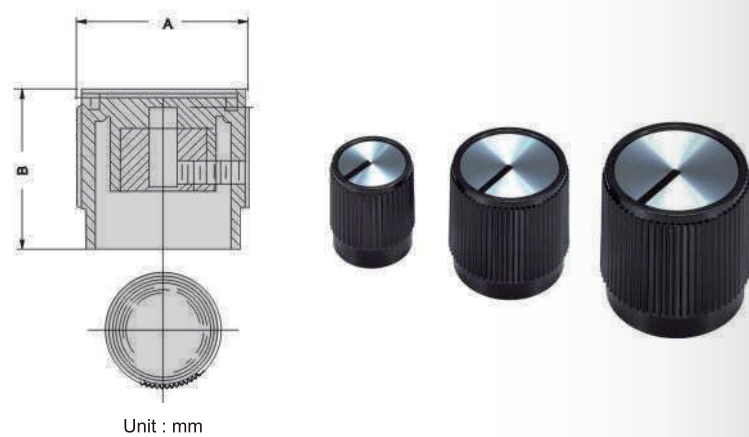

Unit : mm

**Description**

- Material : ABS
- Finish color : Matte black
- Top inlay options : plain, any colors / indicator line / indicator dot

- 材質：ABS塑膠
- 表面顏色：黑色霧面
- 上銘板可選擇素色或任何顏色，加指示線或指示點

PART NO.	A	B	HOLE
41013-1	13.2	12.19	6.4 DIA
41013-2	18.29	14.73	3.2 / 6.4 DIA
41013-3	23.37	16.26	3.2 / 6.4 DIA

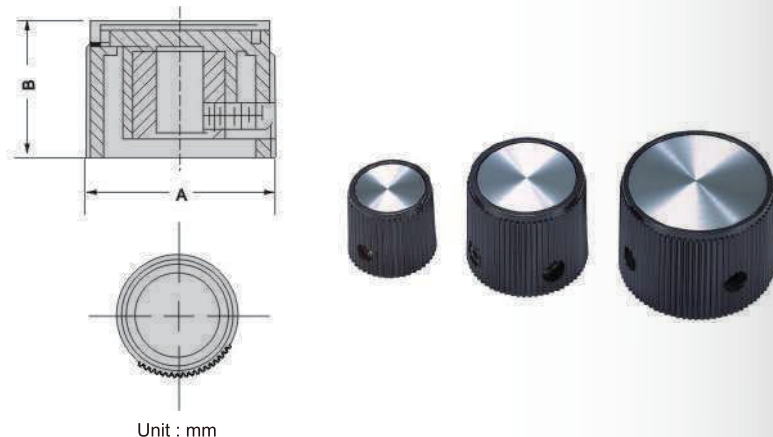

Unit : mm

**Description**

- Material : black phenolic
- Straight knurl with spun aluminum top inlay and skirt

- 材質：黑色電木
- 直齒狀，鋁質上 / 下銘板

PART NO.	A	B	C	D	E	F
41017-1	36	23.1	19.8	1.53	12.4	15
41017-2	36	23.1	19.8	1.53	12.4	15

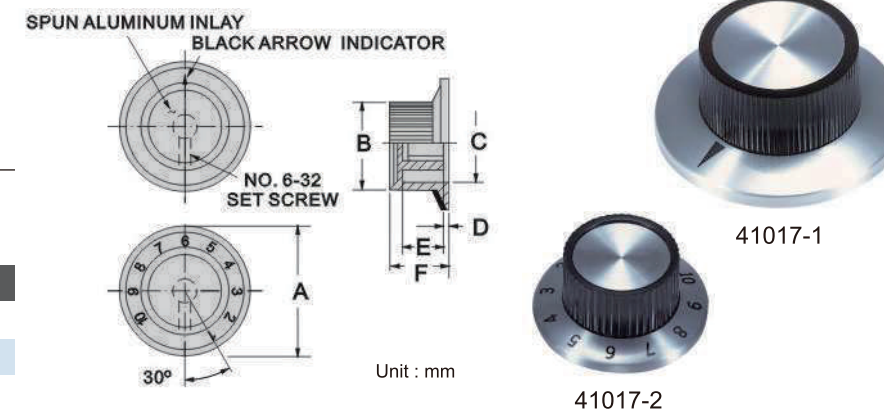

Unit : mm

**Description**

- Material : black phenolic
- With spun aluminum top inlay and straight knurl skirt with 0-10 numerals

- 材質：黑色電木
- 鋁質上/下銘板，下銘板可選擇是否印刻度(0~10)

PART NO.	A	B	C	D	E	F	SHAF HOLE
41019-1	19.8	15.2	12.4	1.53	9.91	14.5	3.2
41019-2	19.8	15.2	12.4	1.53	9.91	14.5	6.4
41019-3	25.4	18.8	18.5	2.29	12.7	15	6.4
41019-4	32.7	25.4	21.8	1.01	12.7	15	6.4

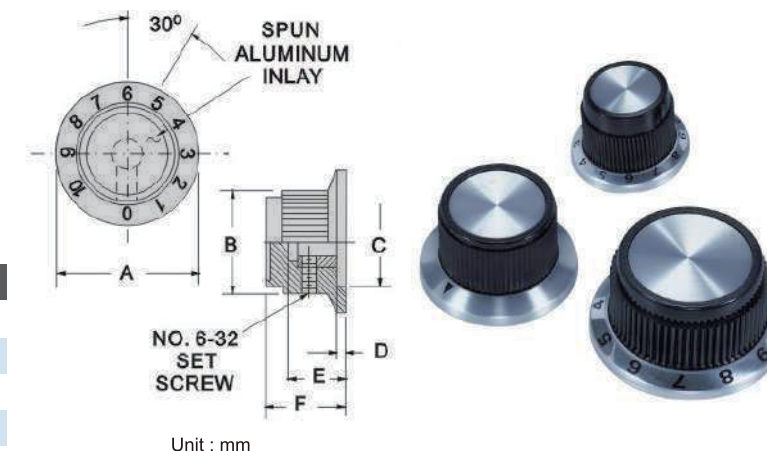

Unit : mm

**Description**

- Material : black phenolic
- Straight knurl with spun, aluminum top inlay and skirt

- 黑色電木
- 直線紋路，鋁質上 / 下銘板(印刻度)

PART NO.	A	B	C	D	E	F
41020-1	29.4	14.2	15.8	2.28	13	17
41020-2	29.4	14.2	15.8	2.28	13	17
41020-3	29.4	14.2	15.8	2.28	13	17

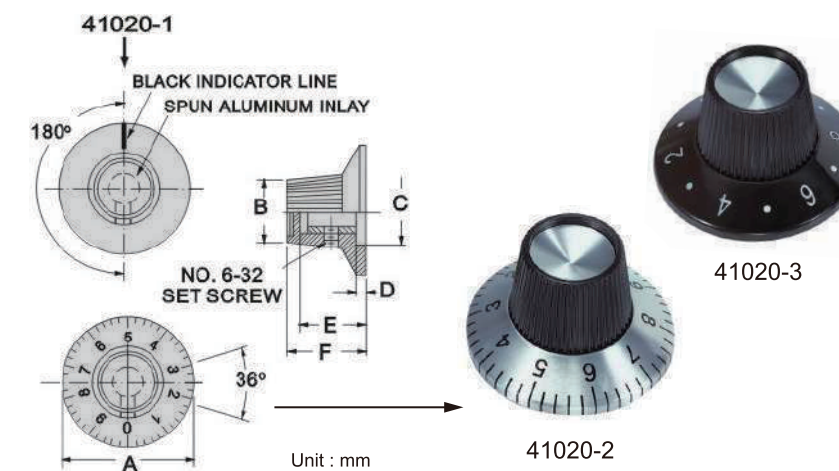

Unit : mm

**Description**

- Material : black phenolic
- With spun aluminum top inlay and straight knurl with indicator line on skirt
- W / O aluminum skirt

- 材質：黑色電木
- 鋁質上銘板，直齒狀，下塑膠加指示線
- 沒有下銘質銘板

PART NO.	A	B	C	D	E	F
41021-1	28.4	14.2	15.8	2.28	13	17

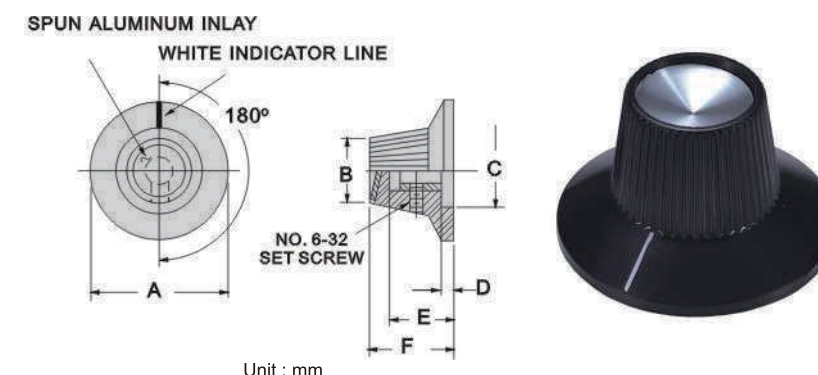

Unit : mm

轉鈕

全鋁及鋁殼旋鈕

指示旋鈕

滑鈕

握把旋鈕

控制旋鈕

機械旋鈕

按鍵旋鈕

雙色旋鈕

DIY旋鈕

及配件

腳墊

轉鈕

全鋁及鋁殼旋鈕

指示旋鈕

滑鈕

握把旋鈕

控制旋鈕

機械旋鈕

按鍵旋鈕

雙色旋鈕

DIY旋鈕

及配件

腳墊

**Description**

- Material : Phenolic
- Finish : Matte black
- One set screw

- 材質：電木
- 表面：黑色霧面
- 鎖一顆螺絲

PART NO.	A	B	C	SHAF HOLE
41023-1	11.2	12	9.8	3.2

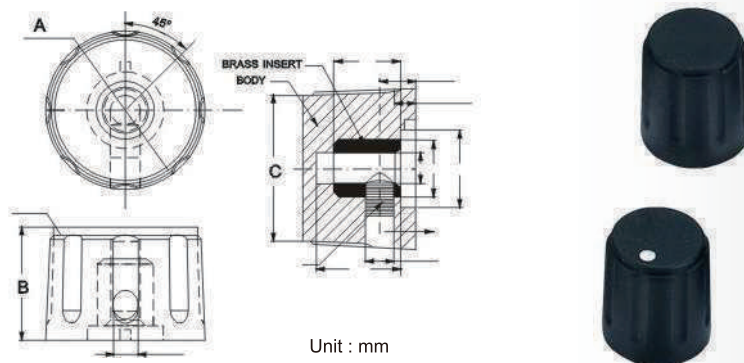

Unit : mm

**Description**

- Material : ABS
- Finish : Matte texture on top
- Knurling on the outside diameter except of 41026-1
- Recess indicator dot on the top
- Shaft hole :  $\phi$  6 mm x 18 teeth

- 材質：ABS塑膠
- 頂部霧面咬花
- 外徑齒狀(41026-1除外)
- 頂部凹槽指示點
- 插梢孔徑： $\phi$  6 mm x 18齒

PART NO.	A	B	C	D
41026-1	45.1	4.5	40.2	23.2
41026-2	33	0	29	13
41026-3	31	0	26	12.8

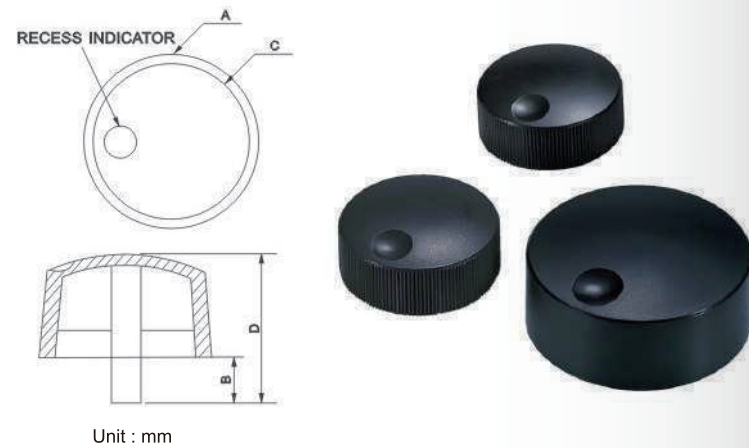

Unit : mm

**Description**

- Material : ABS
- Indicator line on top and side
- Shaft Hole :  $\phi$  6 mm x 18 teeth  
 $\phi$  6 mm x 36 teeth

- 材質：ABS塑膠
- 指示線從頂部延伸至側面
- 插梢孔徑： $\phi$  6 mm x 18齒 /  $\phi$  6 mm x 36齒

PART NO.	A	B	C	Shaft	Finish
41027-1	13.9	16.9	0	36T	Glossy
41027-2	20.2	20.1	3	18T	Glossy
41027-3	35	20.2	5	18T	Light texture

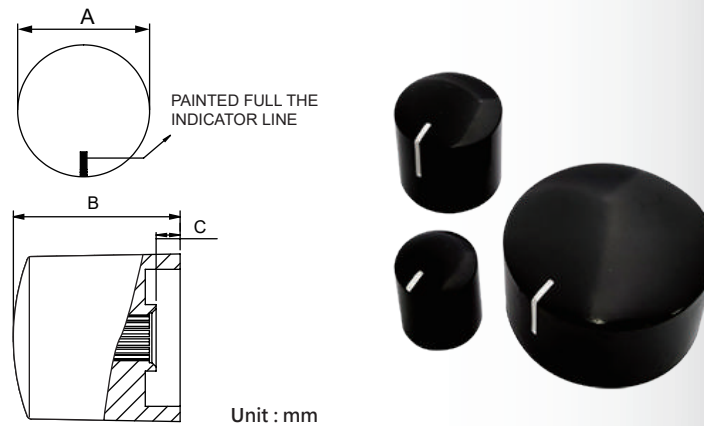

Unit : mm

**Description**

- Material : ABS
- Finish : Matte texture on top
- Hair line on the outside diameter
- Indicator dot on the top
- Shaft hole :  $\phi$  6 mm x 18 teeth (41028-4 36 teeth)

- 材質：ABS塑膠
- 表面：頂部霧面咬花
- 外徑加髮線，頂部加指示點
- 插梢孔徑： $\phi$  6 mm x 18齒 (41028-4 36齒)

PART NO.	A	B	C	D
41028-1	15	17.6	17	3.2
41028-2	17.4	18	17	2.3
41028-3	19.5	17.1	15.7	3.5
41028-4	22	17.8	16.2	3.2
41028-5	30.2	17.8	15.7	3

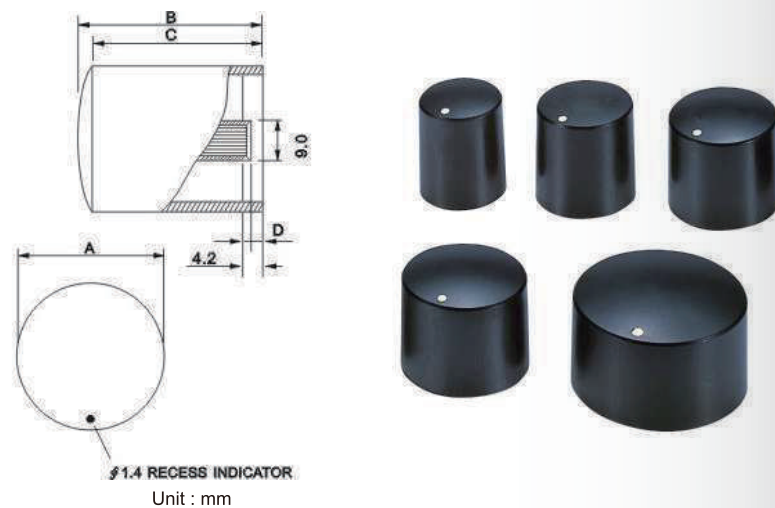

Unit : mm

**Description**

- Material : ABS
- Finish : Texture on top-knurling on outside diameter
- Indicator line on top
- Shaft hole :  $\phi$  6 mm x 18 teeth

- 材質：ABS塑膠
- 表面：外徑頂部咬花面，齒狀
- 頂部加指示線
- 插梢孔徑： $\phi$  6 mm x 18齒

PART NO.	A	B	C	D
41029-1	15.1	13.2	17.4	15.2
41029-2	19.8	18	18	15.4
41029-3	25.1	23	18.5	15.4

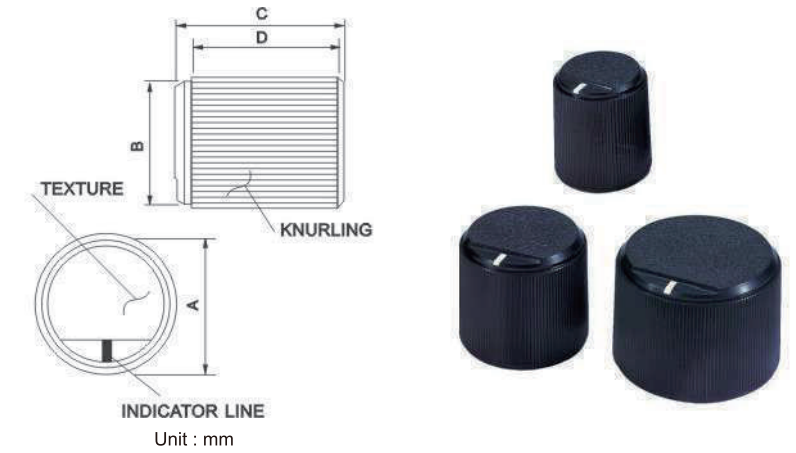

Unit : mm

**Description**

- Material : Phenolic
- With No.6-32 set screw
- Straight knurl outside
- Al. inlay on top

- 材質：電木
- 鎖6-32號螺絲
- 外徑齒狀
- 鋁質上銘板

PART NO.	A	B	C	D	E	F
41031	25.3	24.7	20.3	12	17	3.99

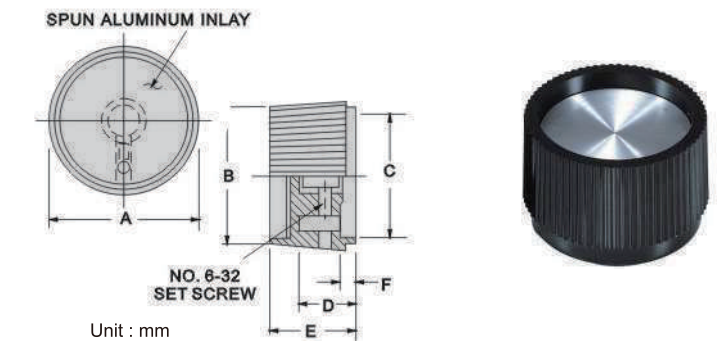

Unit : mm

**Description**

- Material : Phenolic
- With No.6-32 set screw
- Ribbed with white indicator line
- Al. inlay on top

- 材質：黑色電木
- 鎖6-32號螺絲
- 白色指示線
- 鋁質上銘板

PART NO.	A	B	C	D	E	F
41032-1	20	17.6	12.9	2.08	14.7	17.5
41032-2	20	17.6	12.9	2.08	14.7	17.5
41032-3	24.8	22.2	17	1.27	16.1	18.7

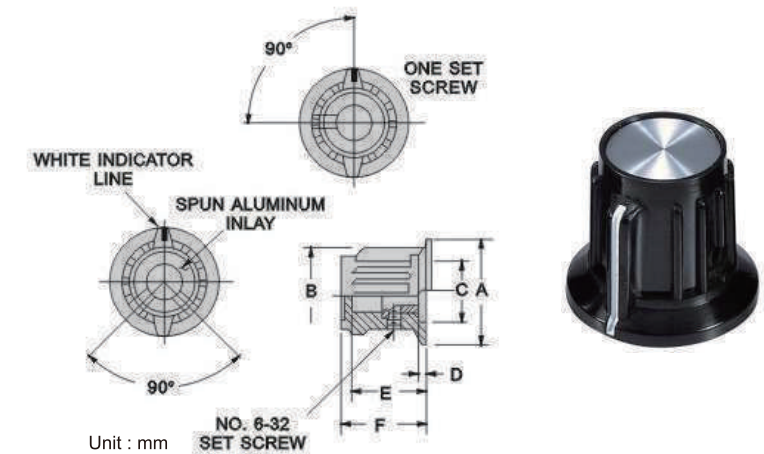

Unit : mm

**Description**

- Material : Phenolic
- With No.6-32 set screw
- Fluted on outside
- Al. cap on top with black indicator line

- 材質：電木
- 鎖6-32號螺絲
- 外觀凹槽狀
- 鋁質上蓋加指示線

PART NO.	A	B	C	D	E	F
41033-1	15	14.6	10	2	9.5	12
41033-2	20	19.4	14.5	2.49	12.5	15.6
41033-3	25	24.3	19	2.5	15.5	17.5

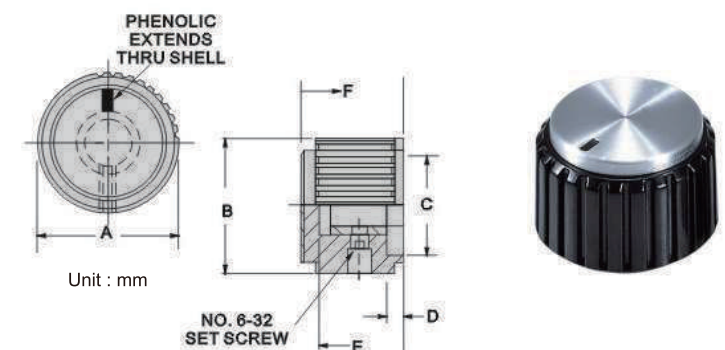

Unit : mm



轉鈕

全鋁及鋁殼旋鈕

指示旋鈕

滑鈕

握把旋鈕

控制旋鈕

機械旋鈕

按鍵旋鈕

雙色旋鈕

DIY旋鈕及配件

腳墊



轉鈕

全鋁及鋁殼旋鈕

指示旋鈕

滑鈕

握把旋鈕

控制旋鈕

機械旋鈕

按鍵旋鈕

雙色旋鈕

DIY旋鈕及配件

腳墊

**Description**

- Material : Phenolic
- With No.6-32 set screw
- Fluted with white indicator line
- Al. cap on top

- 材質：電木
- 鎖6-32號螺絲
- 外觀凹槽狀，側邊加指示線
- 鋁質上蓋

PART NO.	A	B	C	D	E	SHAF. HOLE
41034-1	16	12	2.31	10	12	3.2
41034-2	16	12	2.31	10	12	6.4
41034-3	22.6	18.4	2.49	12.2	13	6.4

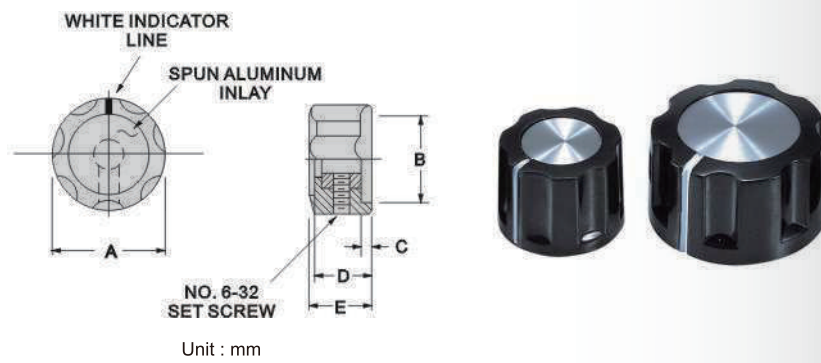

Unit : mm

**Description**

- Material : Phenolic
- White epoxy painted indicator

- 材質：電木
- 白色Epoxy指示線

PART NO.	D	d1	d2	H	h1	h2
41035	38	6	28	18	4	16

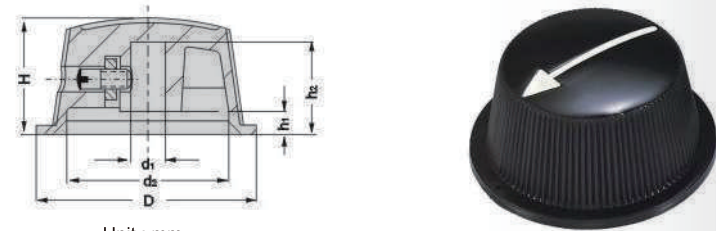

Unit : mm

**Description**

- Material : Phenolic
- With epoxy indicator line
- Brass insert with set screw

- 材質：電木
- 白色Epoxy指示線
- 埋銅，鎖螺絲

PART NO.	D	d1	d2	H	h1	h2
41037	19	6	16	13.5	3	11.5

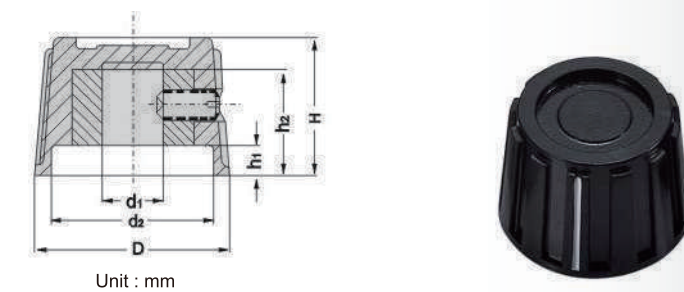

Unit : mm

**Description**

- Material : Phenolic
- Aluminum inlay on top
- With 6-32 set screw
- High Gloss, white indicator line
- Brass insert

- 材質：黑色電木
- 鎖6-32號螺絲
- 鋁質上銘板
- 亮面，白色指示線
- 埋銅粒

PART NO.	A	B	C	D	E	F	G	H
41038-1	14.5	16.5	8	3	13.2	3.2	17	7
41038-2	14.5	16.5	8	3	13.2	6.4	17	7

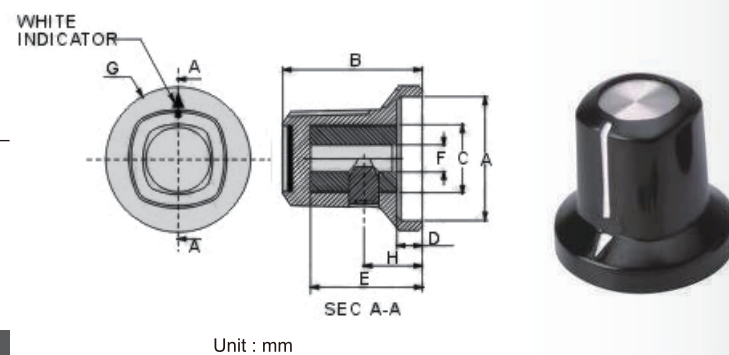

Unit : mm

**Description**

- Material : Phenolic
- With 6-32 set screw
- Straight knurling
- Aluminum top inlay and skirt

- 材質：黑色電木
- 鎖6-32號螺絲
- 齒狀，鋁質上/下銘板

PART NO.	A	B	C	D	E	F	G	H
41039-1	30	14.7	14	3	15.6	19	9.2	6.4

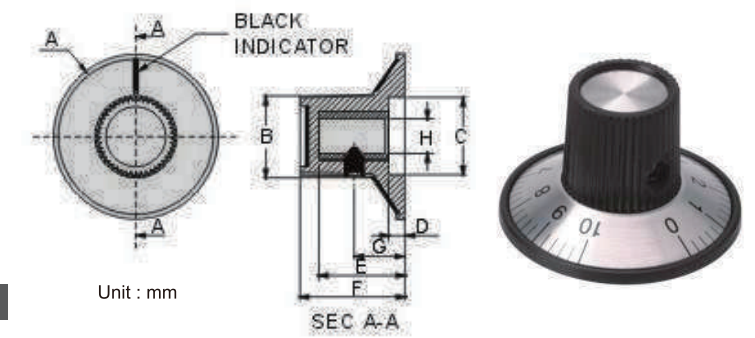

Unit : mm

**Description**

- Material : Phenolic
- With 6-32 set screw
- Aluminum inlay on top
- White indicator line

- 材質：黑色電木
- 鎖6-32號螺絲
- 鋁質上銘板
- 白色指示線

PART NO.	A	B	C	D	E	F	G
41040-1	28.3	17	6.4	3	12.4	15.2	7
41040-2	38.1	20.3	6.4	4.6	17.9	20.8	7

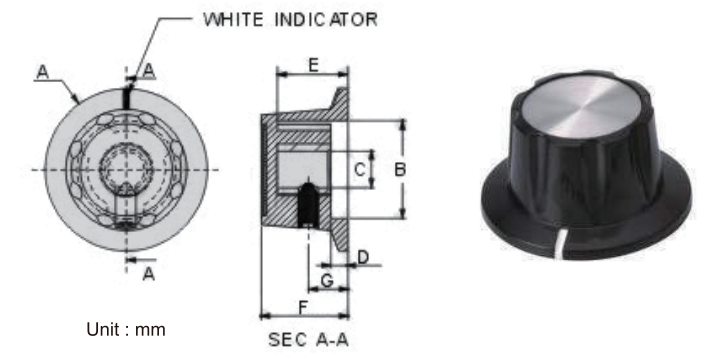

Unit : mm

**Description**

- Material : Phenolic
- Set screw
- Alum inlay on top
- High Gloss, White indicator dot on top

- 材質：黑色電木
- 鎖螺絲
- 鋁質上銘板
- 亮面，白色指示點於頂部

PART NO.	A	B	C	D	E	F	G	H
41041-1	17.8	16.3	14.6	3.5	3.2	11.9	7.3	13.5
41041-2	17.8	16.3	14.6	3.5	6.4	11.9	7.3	13.5

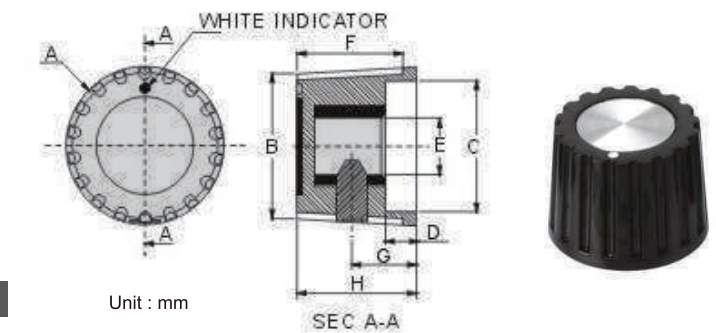

Unit : mm

**Description**

- Material : Phenolic
- With 6-32 & 4-40 set screw
- Finish with light texture, white indicator on top
- Shaft hole :  $\phi$  6.4 x 3.2 mm

- 材質：黑色電木
- 鎖6-32號與4-40號螺絲
- 表面細咬花，白色指示點於頂部
- 插梢尺寸： $\phi$  6.4 x 3.2 mm

PART NO.	A	B	C	D	E	F	G
41042-1	15	11.8	9.6	2	11.6	13.9	5
41042-2	20	15.7	12.1	1.5	12.9	15.3	6
41042-3	29.7	24.6	19.8	2.3	14.5	17.1	7
41042-4	34.8	28.5	23.7	2.5	13.7	17.9	7
41042-5	39.8	33.2	27.7	3	15.6	19	6.9

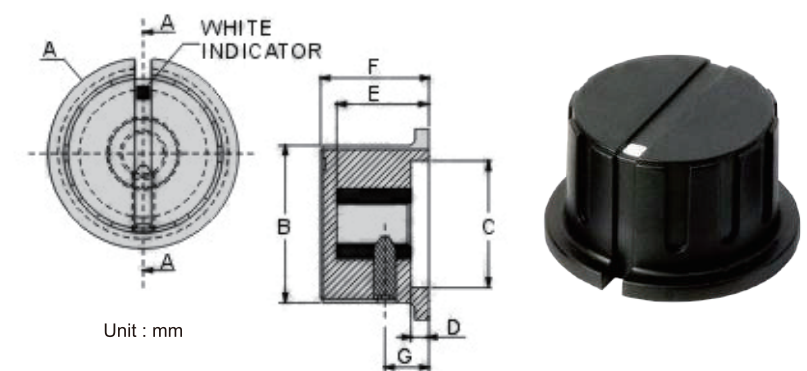

Unit : mm



轉鈕  
turning knobs

全鋁及鋁殼旋鈕  
machined aluminum & shell knobs

指示旋鈕  
pointer knobs

滑鈕  
slide control knobs

握把旋鈕  
band knobs

控制旋鈕  
control knobs

機械旋鈕  
fasten knobs

按鍵旋鈕  
push knobs

雙色旋鈕  
Double-shot knobs

Diy旋鈕及配件  
DIY control knobs & accessories

腳墊  
feet pad

轉鈕  
turning knobs

全鋁及鋁殼旋鈕  
machined aluminum & shell knobs

指示旋鈕  
pointer knobs

滑鈕  
slide control knobs

握把旋鈕  
band knobs

控制旋鈕  
control knobs

機械旋鈕  
fasten knobs

按鍵旋鈕  
push knobs

雙色旋鈕  
Double-shot knobs

Diy旋鈕及配件  
DIY control knobs & accessories

腳墊  
feet pad



**Description**

- Material : ABS
- Finish : Light texture, Matt
- White indicator line on top
- Shaft hole :  $\phi$  6mm x 18 teeth  
D type  $\phi$  6 x 4.5mm

- 材質：ABS塑膠
- 表面：細咬花，霧面
- 頂部加白色指示線
- 插梢尺寸： $\phi$  6 mm  $\times$  18齒或  
D型， $\phi$  6  $\times$  4.5 mm

PART NO.	A	B	C	D
41043-1	13	13	11.6	3.5
41043-2	18.5	14	15.5	2.5
41043-3	23	14	20	2.5

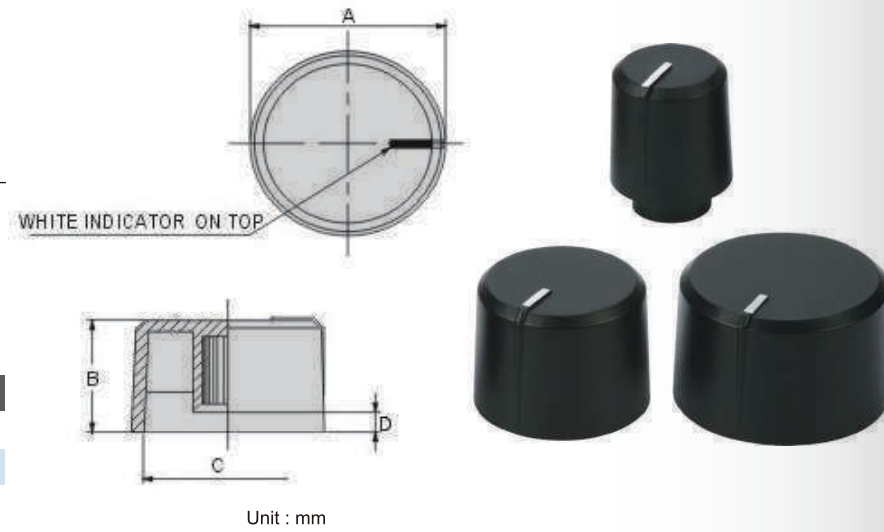

**Description**

- Material : ABS
- Finish : matt, Light texture
- Plastic cap on top, color option
- Collected knob with brass insert
- Shaft hole :  $\phi$  6 mm x 18 teeth

- 材質：ABS塑膠
- 表面：霧面，細咬花
- 塑膠上蓋，顏色可選擇
- 埋銅粒
- 插梢尺寸： $\phi$  6 mm  $\times$  18齒

PART NO.	A	B	C
41044-1	10	13.5	6.8
41044-2	11.5	13.5	6.8
41044-3	12.5	13.5	6.8
41044-4	15.8	13.7	6.8

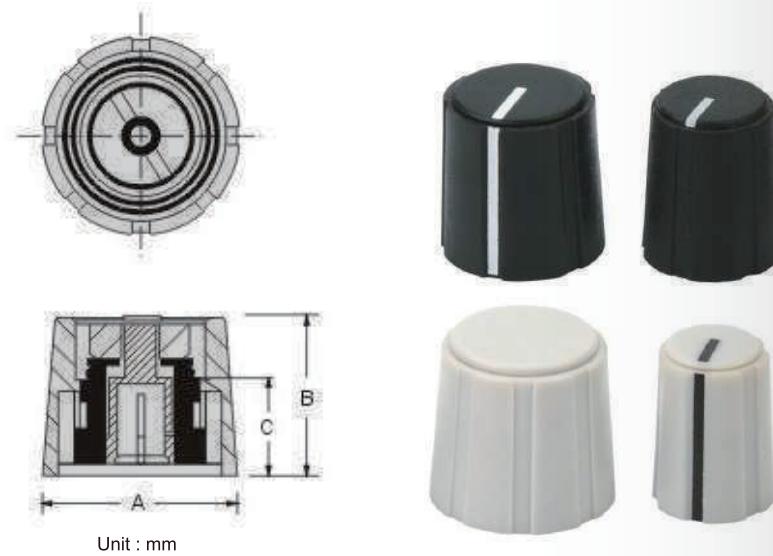

**Description**

- Material : ABS
- Finish : gloss
- indicator line or dot
- Shaft hole :  $\phi$  6 mm x 18 teeth

- 材質：ABS塑膠
- 表面：亮面
- 指示線或指示點
- 插梢尺寸： $\phi$  6 mm  $\times$  18齒

PART NO.	A	B	C	D
41045-1	10.7	13.5	1.5	6.6
41045-2	13	17.7	5	10
41045-3	15	17.7	1.5	11.2
41045-4	20	20	0	12

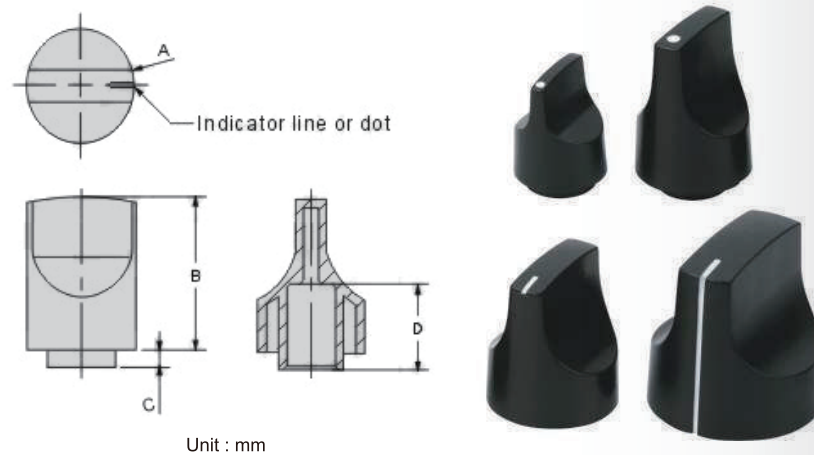

**Description**

- Material : ABS
- Finish : Gloss
- White indicator line on side
- Shaft hole : D type  $\phi$  6 X 4.5 mm  
 $\phi$  6 mm x 18 teeth

- 材質：ABS
- 表面：亮面
- 側邊白色指示線
- 插梢尺寸：D型  $\phi$  6 X 4.5 mm  
 $\phi$  6 mm  $\times$  18 齒

PART NO.	A	B	C	D	E	F
41046-1	19	11.9	9.7	2.6	9	16.6
41046-2	25.4	14.4	11.9	3.2	9.2	21.6

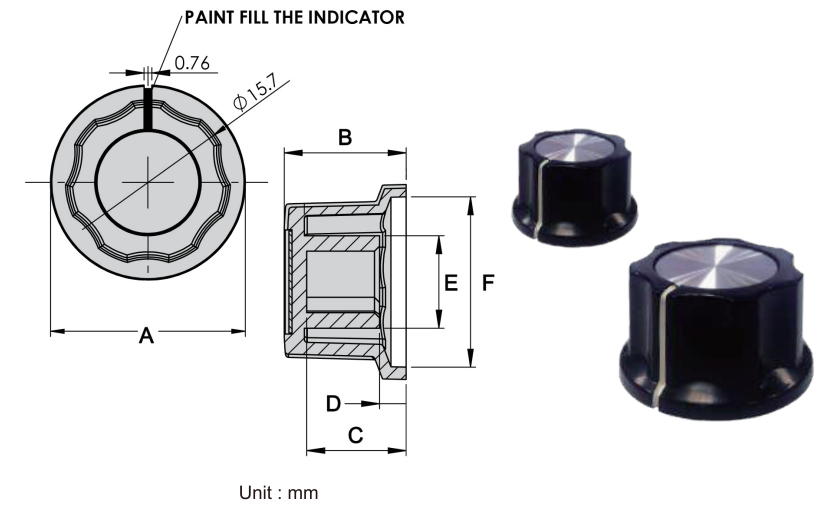

轉鈕

轉鈕

全鋁及鋁殼旋鈕

全鋁及鋁殼旋鈕

指示旋鈕

指示旋鈕

滑鈕

滑鈕

握把旋鈕

握把旋鈕

控制旋鈕

控制旋鈕

機械旋鈕

機械旋鈕

按鍵鈕

按鍵鈕

雙色旋鈕

雙色旋鈕

DIY旋鈕及配件

DIY旋鈕及配件

腳墊

腳墊



Description

- Material : Aluminum shell with plastic insert
- Finish : Anodized black or natural
- With two No. 6-32 set screws
- 6 flute design with indicator line
- Solid aluminum knob is available

- 材質：鋁質外殼植入塑膠
- 黑色或原色電解
- 六個凹槽設計，側邊加指示線
- 鎖兩支6-32號螺絲
- 可供應實心鋁質旋鈕

PART NO.	COLOR	A	B	C	D	E	F	G
42001-1	NATURAL	12.7	10.9	9.65	10.9	16	13	10.9
42001-2	BLACK	12.7	10.9	9.65	10.9	16	13	10.9
42001-3	NATURAL	19	16.5	15	16.8	16	13	10.9
42001-4	BLACK	19	16.5	15	16.8	16	13	10.9
42001-5	NATURAL	23.9	20.8	18	20.8	16	13	10.9
42001-6	BLACK	23.9	20.8	18	20.8	16	13	10.9

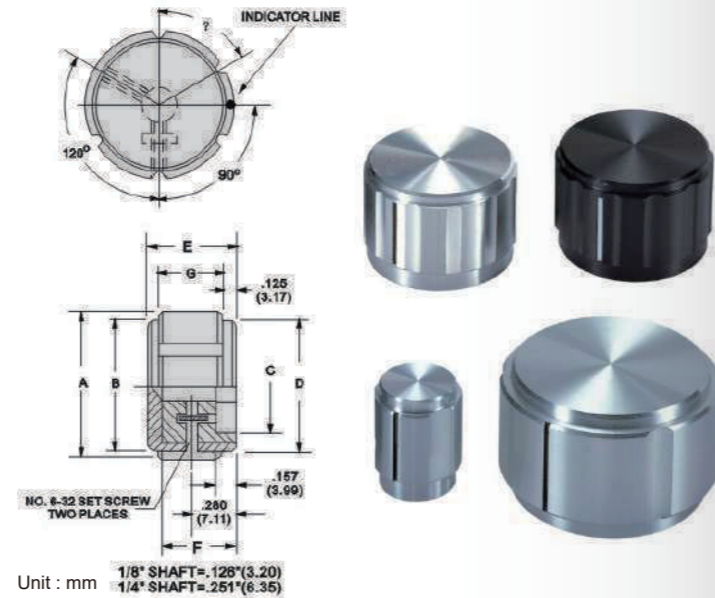

Unit : mm

Description

- Material : Aluminum
- Finish : Anodized black or natural
- With two 4-40 set screws
- Control knob with sawcut indicator

- 材質：全鋁旋鈕
- 黑色或原色電解
- 側邊凹槽指示線
- 鎖兩支6-32號螺絲
- 可供應實心鋁質旋鈕

PART NO.	COLOR	A	B	C	D	E	F	G
42002-1	NATURAL	12.7	5.08	9.4	3.3	3.05	9	19
42002-2	NATURAL	12.7	5.08	9.4	6.35	3.05	9	19
42002-3	BLACK	12.7	5.08	9.4	3.3	3.05	9	19
42002-4	BLACK	12.7	5.08	9.4	6.35	3.05	9	19
42002-5	NATURAL	15.8	5.08	9.9	3.3	3.05	9	19
42002-6	NATURAL	15.8	5.08	9.9	6.35	3.05	9	19
42002-7	BLACK	15.8	5.08	9.9	3.3	3.05	9	19
42002-8	BLACK	15.8	5.08	9.9	6.35	3.05	9	19
42002-9	NATURAL	19	5.08	13	6.35	3.05	9	22.9
42002-10	BLACK	19	5.08	13	6.35	3.05	9	22.9
42002-11	NATURAL	23.9	5.08	18	6.35	3.05	9	22.9
42002-12	BLACK	23.9	5.08	18	6.35	3.05	9	22.9

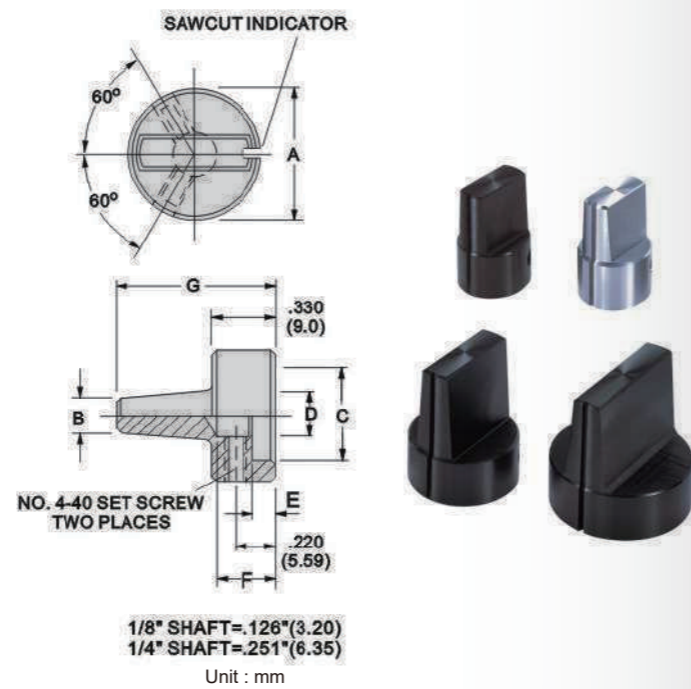

Unit : mm

Description

- Material : Aluminum shell with plastic insert
- Finish : Anodized black or natural
- With two NO. 6-32 set screws
- Diamond Knurl with indicator line
- Solid aluminum knob is available

- 材質：鋁質外殼植入塑膠
- 黑色或原色電解
- 鑽石紋路，側邊加指示線
- 鎖兩支6-32號螺絲
- 可供應實心鋁質旋鈕

PART NO.	COLOR	A	B	C	D	E	F	G
42003-1	NATURAL	13.3	10.9	9.65	10.9	16	13	11.9
42003-2	BLACK	13.3	10.9	9.65	10.9	16	13	11.9
42003-3	NATURAL	19.5	16.8	15	16.8	16	13	11.9
42003-4	BLACK	19.5	16.8	15	16.8	16	13	11.9
42003-5	NATURAL	24.7	20.8	18	20.8	16	13	11.9
42003-6	BLACK	24.7	20.8	18	20.8	16	13	11.9
42003-7	NATURAL	32.3	28.2	24.9	28.2	19	16	15
42003-8	BLACK	32.3	28.2	24.9	28.2	19	16	15

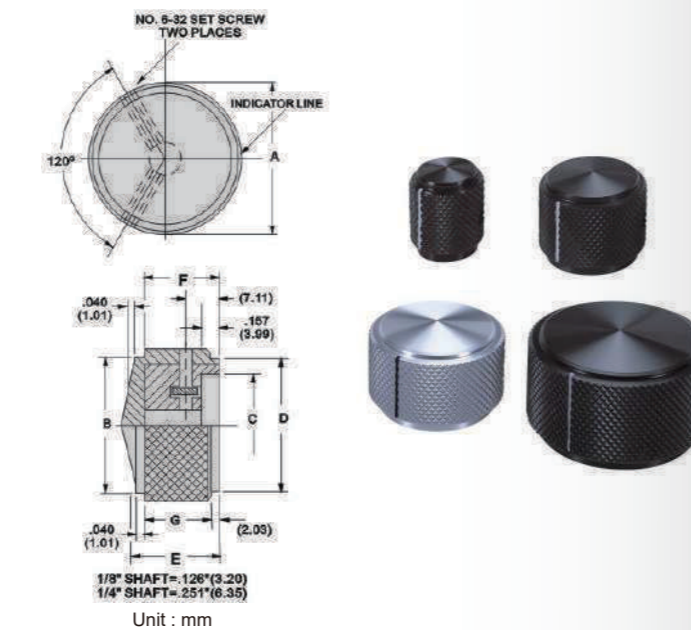

Unit : mm

Description

- Material : Aluminum shell with plastic insert
- Finish : Anodized black or natural
- With two No. 6-32 set screws
- Control knob with straight knurl and top line indicator
- Solid aluminum knob is available

- 材質：鋁質外殼植入塑膠
- 黑色或原色電解
- 鎖兩支6-32號螺絲
- 直齒狀，頂部加指示線
- 可供應實心鋁質旋鈕

PART NO.	COLOR	A	B	C	D	E	F	G
42004-1	NATURAL	12.7	10.9	9.9	11.9	20	16	15.5
42004-2	BLACK	12.7	10.9	9.9	11.9	20	16	15.5
42004-3	NATURAL	19.9	19.3	15.9	19.1	16.1	14	11.5
42004-4	BLACK	19.9	19.3	15.9	19.1	16.1	14	11.5
42004-5	NATURAL	23.6	22.1	18	22.9	20	16	15.5
42004-6	BLACK	23.6	22.1	18	22.9	20	16	15.5

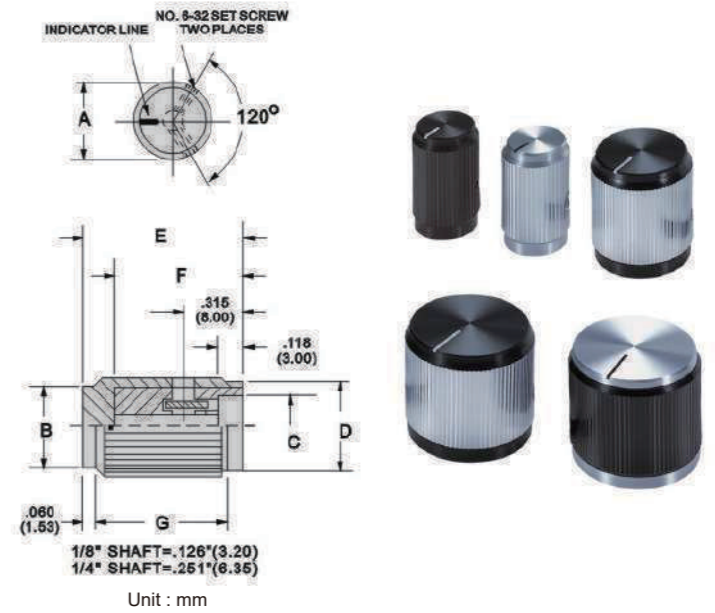

Unit : mm

Description

- Material : Aluminum shell with plastic insert
- Finish : Anodized color by request
- With two No. 6-32 set screws
- Straight knurl with arrow head indicator
- Solid aluminum knob is available

- 材質：鋁質外殼植入塑膠
- 電解顏色可選擇
- 鎖兩支6-32號螺絲
- 直齒狀，箭頭型指示線
- 可供應實心鋁質旋鈕

PART NO.	COLOR	A	B	C	D	E	F	G
42005-1	NATURAL	12.7	11.4	9.65	11.4	16	13	11.7
42005-2	BLACK	12.7	11.4	9.65	11.4	16	13	11.7
42005-3	NATURAL	19	17.3	15	17.8	16	13	11.7
42005-4	BLACK	19	17.3	15	17.8	16	13	11.7

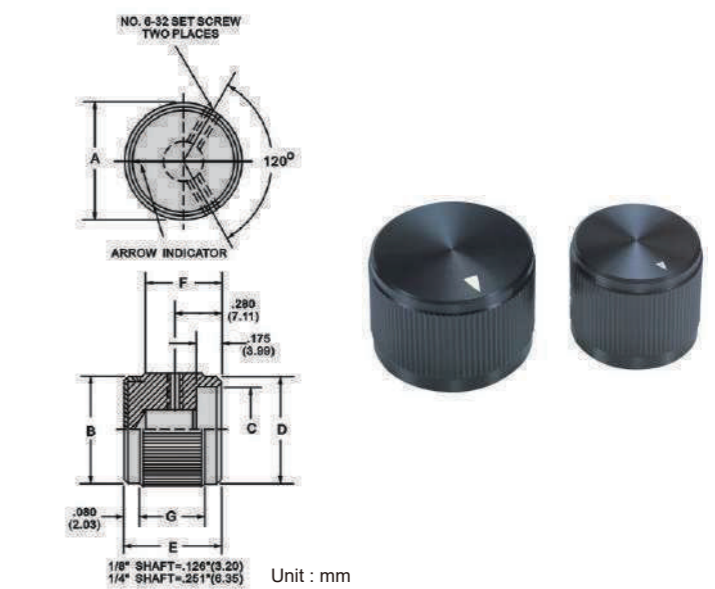

Unit : mm

Description

- Material : Aluminum shell with plastic insert
- Finish : Anodized black or natural
- With two No. 6-32 set screws
- Straight knurl with top and side indicator
- Solid aluminum knob is available

- 材質：鋁質外殼植入塑膠
- 黑色或原色電解
- 鎖兩支6-32號螺絲
- 直齒狀，指示線從頂部延伸至側邊
- 可供應實心鋁質旋鈕

PART NO.	COLOR	A	B	C	D	E	F	G
42006-1	NATURAL	12.7	11.4	9.65	7.11	16	13	13.5
42006-2	BLACK	12.7	11.4	9.65	7.11	16	13	13.5
42006-3	NATURAL	19	17.8	14.9	7.11	16	13	13.5
42006-4	BLACK	19	17.8	14.9	7.11	16	13	13.5
42006-5	NATURAL	23.9	22.3	18	7.11	16	13	13.5
42006-6	BLACK	23.9	22.3	18	7.11	16	13	13.5
42006-7	NATURAL	31.7	30.5	24.9	7.11	16	13	13.5
42006-8	BLACK	31.7	30.5	24.9	7.11	16	13	13.5

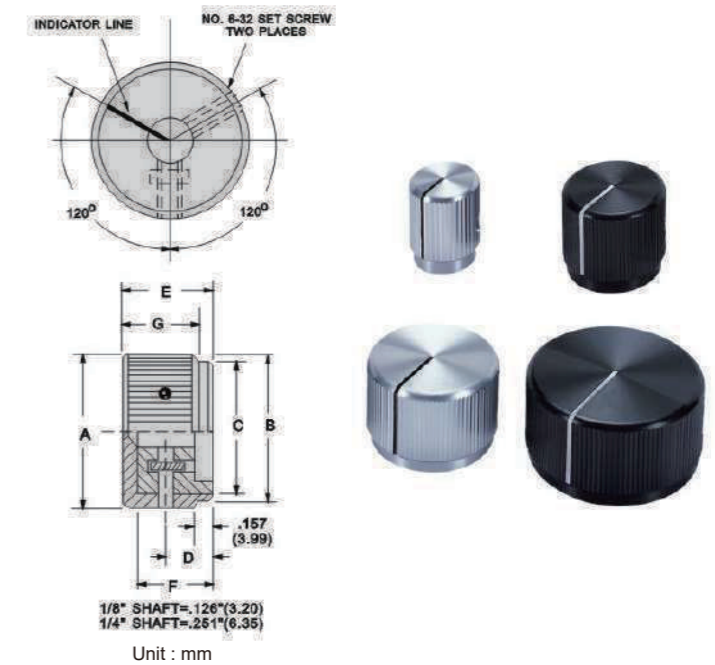

Unit : mm

轉鈕

全鋁及鋁殼旋鈕

指示旋鈕

滑鈕

握把旋鈕

控制旋鈕

機械旋鈕

按鍵旋鈕

雙色旋鈕

Diy旋鈕及配件

腳墊

轉鈕

全鋁及鋁殼旋鈕

指示旋鈕

滑鈕

握把旋鈕

控制旋鈕

機械旋鈕

按鍵旋鈕

雙色旋鈕

Diy旋鈕及配件

腳墊

**Description**

- Material : Aluminum shell with plastic insert
- Finish : Anodized black or natural
- With two No. 6-32 set screws
- Serrated diamond trim cut with dot indicator
- Solid aluminum knob is available

- 材質：鋁質外殼植入塑膠
- 黑色或原色電解
- 鎖兩支6-32號螺絲
- 鋸齒狀鑽石切邊加指示點
- 可供應實心鋁質旋鈕

PART NO.	A	B	C	D	E	F	G
42007-1	9.4	7.11	7.11	2.54	5.08	6.1	7.6
42007-2	9.4	7.11	7.11	2.54	5.08	9.1	11.4
42007-3	12.7	10.4	9.65	3.05	7.11	13	15.2
42007-4	19	16.5	14.9	3.05	7.11	13	15.2

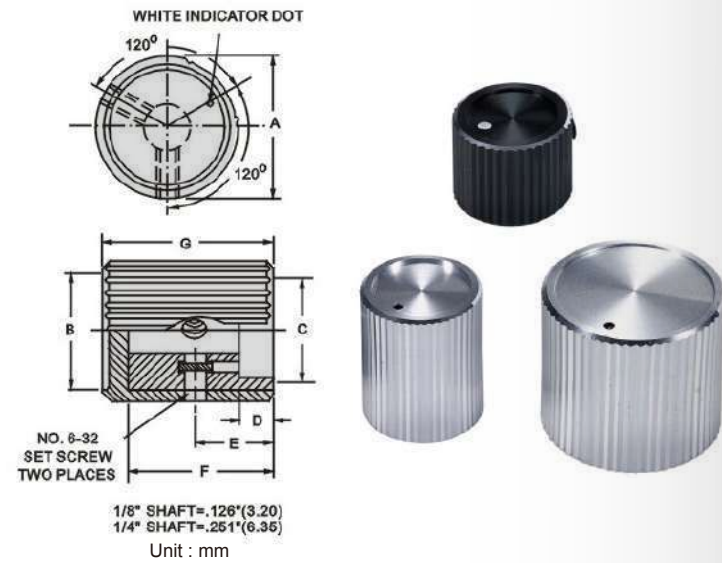

**Description**

- Material : Aluminum shell with plastic insert
- Finish : Anodized black or natural
- With two No. 6-32 set screws
- Square serration with indicator line
- Solid aluminum knob is available

- 材質：鋁質外殼植入塑膠
- 黑色或原色電解
- 鎖兩支6-32號螺絲
- 方格鋸齒狀加指示線
- 可供應實心鋁質旋鈕

PART NO.	COLOR	A	B	C	D	E	F	G
42008-1	NATURAL	12.7	10.9	9.65	10.9	7.11	13	16
42008-2	BLACK	12.7	10.9	9.65	10.9	7.11	13	16
42008-3	NATURAL	19	16.5	14.9	16.7	7.11	13	16
42008-4	BLACK	19	16.5	14.9	16.7	7.11	13	16
42008-5	NATURAL	23.9	20.8	18	21	7.11	13	16
42008-6	BLACK	23.9	20.8	18	21	7.11	13	16
42008-7	NATURAL	31.7	28.1	24.8	28.1	7.11	13	19
42008-8	BLACK	31.7	28.1	24.8	28.1	7.11	13	19

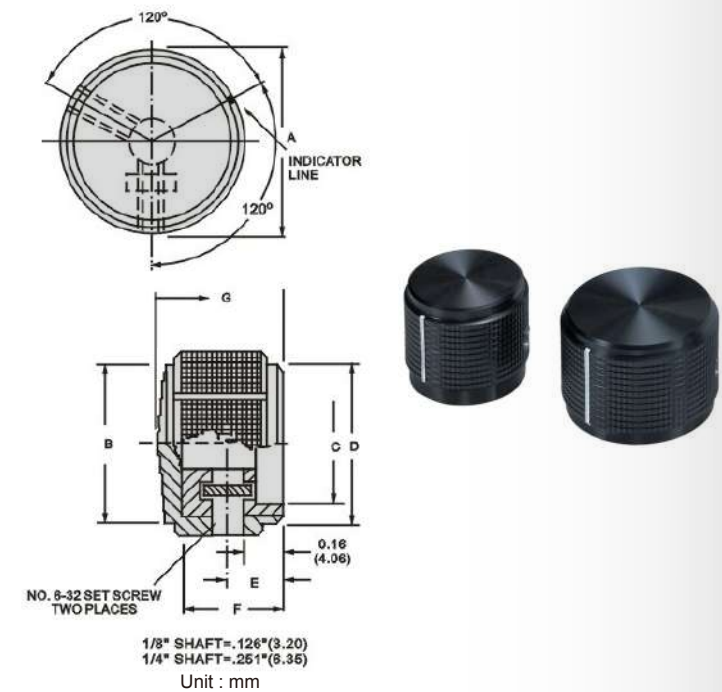

**Description**

- Material : Aluminum shell with plastic insert
- Finish : Anodized black or natural
- With No. 6-32 set screws
- Diamond knurl with indicator line
- Solid aluminum knob is available

- 材質：鋁質外殼植入塑膠
- 黑色或原色電解
- 鎖6-32號螺絲
- 鑽石紋路加指示線
- 可供應實心鋁質旋鈕

PART NO.	D	d1	d2	H	h1	h2
42009-1	18.6	6	13	12	3	9.5
42009-2	22.8	6	14	13	3	11
42009-3	32.5	6	15.5	14	3	12.5
42009-4	38.4	6	33	16	3	13.5

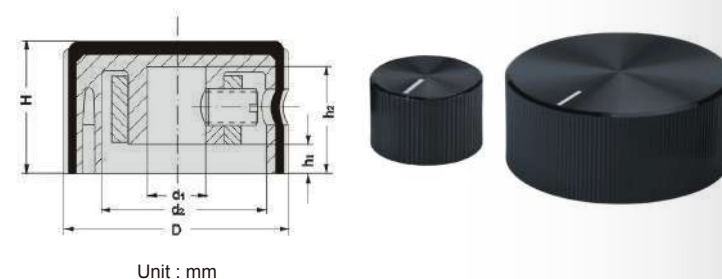

**Description**

- Material : Plastic insert with aluminum cap
- With lateral screw fixing
- With indicator line on top
- Solid aluminum knob is available

- 材質：鋁質外殼植入塑膠
- 螺絲固定於側邊
- 指示線於頂部
- 可供應實心鋁質旋鈕

PART NO.	D	d	H	h
42010-1	12	4	7	5.6
42010-2	12	6	7	5.6

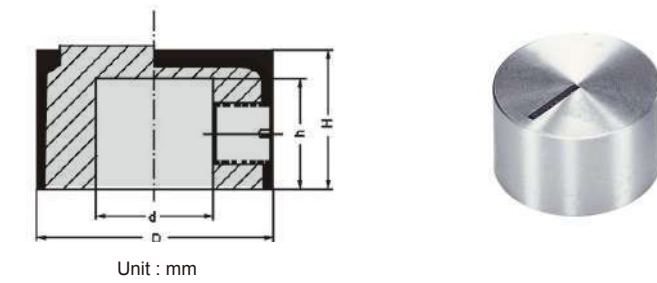

**Description**

- Aluminum cap with ABS plastic insert
- Set screw with steel ring
- With indicator line

- 材質：鋁質外殼植入塑膠
- 螺絲加鐵圈
- 指示線於頂部

PART NO.	D	d1	d2	H	h1	h2
42011-1	18	6	13	12	3	9.5
42011-2	22.2	6	14	13	3	11
42011-3	31.9	6	15.5	14	3	12.5
42011-4	37.8	6	33	16	3	13.5

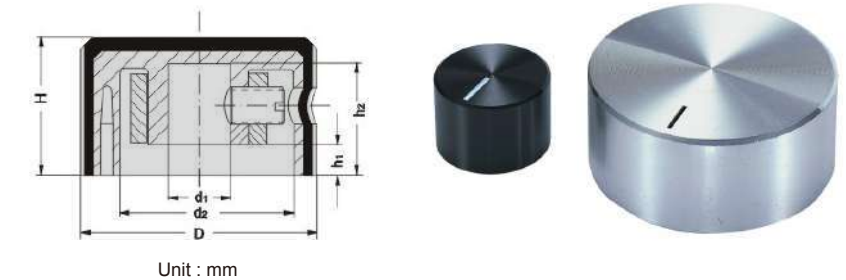

**Description**

- Aluminum cap with ABS plastic insert
- Set screw with steel ring
- With indicator line

- 材質：鋁質外殼植入ABS塑膠
- 螺絲加鐵圈
- 指示線於頂部

PART NO.	D	d1	d2	H	h1	h2
42012-1	18.6	6	13	12	3	9.5
42012-2	22.8	6	14	13	3	11
42012-3	32.5	6	15.5	14	3	12.5
42012-4	38.4	6	33	16	3	13.5

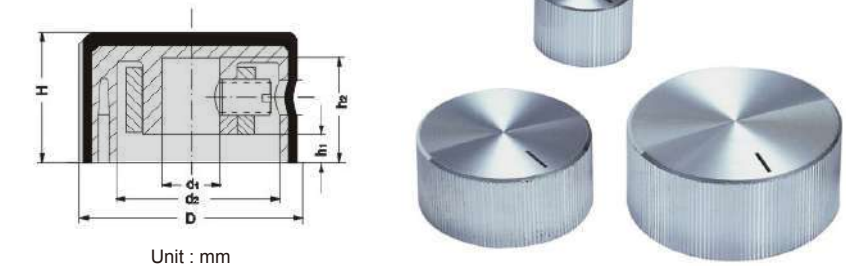

**Description**

- Aluminum cap with ABS plastic insert
- With set screw

- 材質：鋁質外殼植入ABS塑膠
- 鎖螺絲
- 指示線於頂部

PART NO.	D	d	H	h
42013	14	4	11.2	7.5

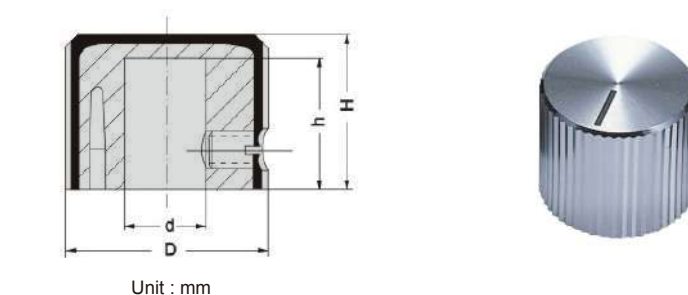

轉鈕  
全鋁及鋁殼旋鈕  
指示旋鈕  
滑鈕  
握把旋鈕  
控制旋鈕  
機械旋鈕  
按鍵旋鈕  
雙色旋鈕  
DIY旋鈕及配件  
腳墊

轉鈕  
全鋁及鋁殼旋鈕  
指示旋鈕  
滑鈕  
握把旋鈕  
控制旋鈕  
機械旋鈕  
按鍵旋鈕  
雙色旋鈕  
DIY旋鈕及配件  
腳墊



Description

- Material : Aluminum
- 6 Flute design with spun aluminum top inlay and skirt with indicator line

- 材質：鋁質
- 六個凹槽設計
- 鋁質上/下銘板與指示線

PART NO.	COLOR	A	B	C	D	E	F	G	SHAF HOLE
42015-1	NATURAL	12.7	10.9	9.65	18.8	16	13	10.9	3.2
42015-2	NATURAL	12.7	10.9	9.65	18.8	16	13	10.9	6.4
42015-3	BLACK	12.7	10.9	9.65	18.8	16	13	10.9	3.2
42015-4	BLACK	12.7	10.9	9.65	18.8	16	13	10.9	6.4
42015-5	NATURAL	19	16.5	15	28.4	16	28.4	7.11	6.4
42015-6	BLACK	19	16.5	15	28.4	16	28.4	7.11	6.4
42015-7	NATURAL	23.9	20.8	18	35.5	16	28.4	7.11	6.4
42015-8	BLACK	23.9	20.8	18	35.5	16	28.4	7.11	6.4

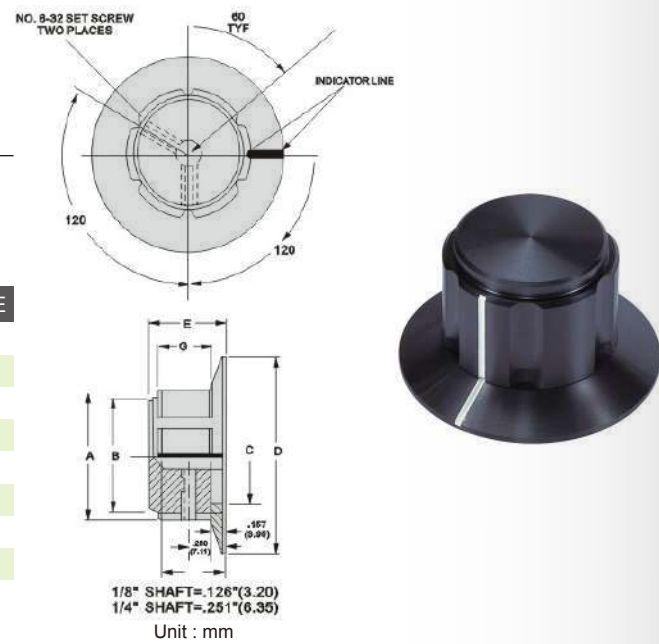

Description

- Material : Aluminum
- 3 Flute design with aluminum skirt and indicator line

- 材質：鋁質
- 三個凹槽設計
- 鋁質上/下銘板與指示線

PART NO.	COLOR	A	B	C	D	E	F	G	SHAF HOLE
42018-1	NATURAL	12.7	10.9	9.65	19	16	12.9	10.9	3.2
42018-2	NATURAL	12.7	10.9	9.65	19	16	12.9	10.9	6.4
42018-3	BLACK	12.7	10.9	9.65	19	16	12.9	10.9	3.2
42018-4	BLACK	12.7	10.9	9.65	19	16	12.9	10.9	6.4
42018-5	NATURAL	19	16.5	14.9	28.4	16	12.9	10.9	6.4
42018-6	BLACK	19	16.5	14.9	28.4	16	12.9	10.9	6.4
42018-7	NATURAL	23.9	20.8	18	35.6	16	12.9	10.9	6.4
42018-8	BLACK	23.9	20.8	18	35.6	16	12.9	10.9	6.4

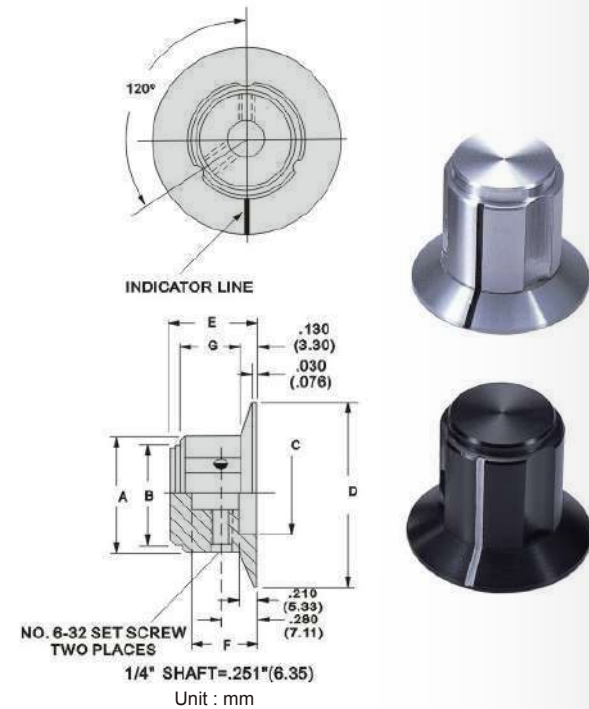

Description

- Material : Aluminum
- Plain body with top and side sawcut indicator

- 材質：鋁質
- 素面，鋸齒狀
- 頂部與側邊指示線

PART NO.	COLOR	A	B	C	D	E
42020-1	NATURAL	12.7	9.65	3.05	8.64	14.2
42020-2	NATURAL	19	14.9	3.05	14.7	14.2
42020-3	NATURAL	23.9	18	3.05	19.8	14.2
42020-4	NATURAL	31.8	24.9	3.05	27.7	14.2

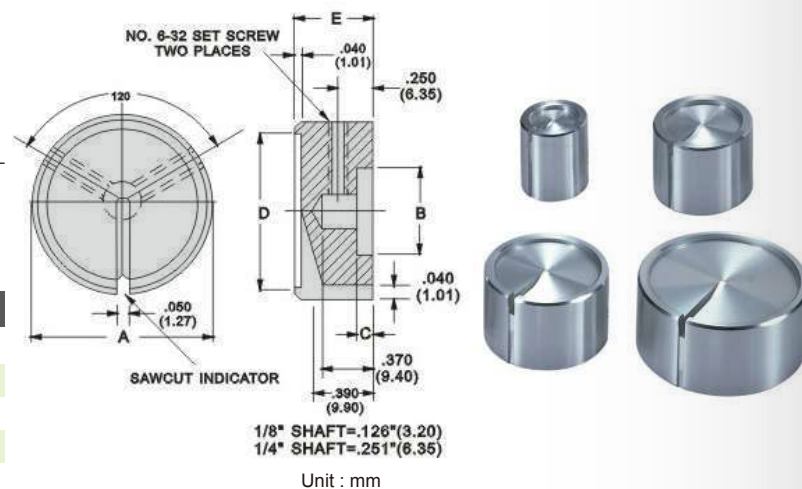

Description

- Material : Aluminum
- Straight knurl with indicator line on top, and skirt

- 材質：鋁質
- 直齒狀
- 指示線從頂部延伸至下銘板

PART NO.	COLOR	A	B	C	D	E	F	G	SHAF HOLE
42021-1	NATURAL	12.7	7.11	9.65	19	4.07	16	13	3.2
42021-2	NATURAL	12.7	7.11	9.65	19	4.07	16	13	6.4
42021-3	BLACK	12.7	7.11	9.65	19	4.07	16	13	3.2
42021-4	BLACK	12.7	7.11	9.65	19	4.07	16	13	6.4
42021-7	NATURAL	19	7.11	14.9	28.7	4.07	16	13	6.4
42021-8	BLACK	19	7.11	14.9	28.7	4.07	16	13	6.4
42021-10	NATURAL	23.9	7.11	18	35.5	4.07	16	13	6.4
42021-11	BLACK	23.9	7.11	18	35.5	4.07	16	13	6.4

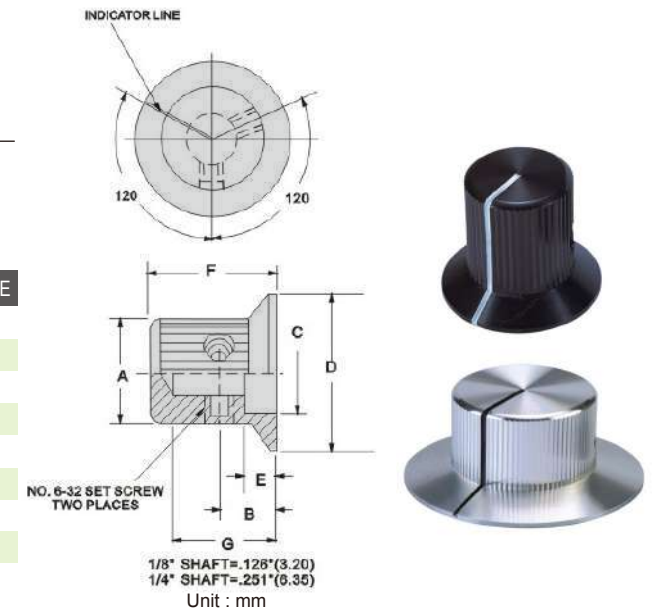

Description

- Material : Aluminum
- Straight knurl with or Without fingertip spinner

- 材質：鋁質
- 直齒狀
- 可選擇頂部是否加圓型凹槽

PART NO.	COLOR	A	B	C	D	E	F	G	
WITHOUT INDICATOR 無指示線									
42023-1	NATURAL	44.4	39.4	34.8	41.9	16	13	12.2	
42023-2	BLACK	44.4	39.4	34.8	41.9	16	13	12.2	
42023-3	NTL.&BLK.	44.4	39.4	34.8	41.9	16	13	12.2	
42023-4	BLK.&NTL.	44.4	39.4	34.8	41.9	16	13	12.2	
WITH INDICATOR 加指示線									
42023-5	NATURAL	44.4	39.4	34.8	41.9	16	13	12.2	
42023-6	BLACK	44.4	39.4	34.8	41.9	16	13	12.2	
WITH SPINNER / WITHOUT INDICATOR 圓形凹槽 / 不加指示線									
42023-7	NATURAL	44.4	39.4	34.8	41.9	16	13	12.2	
42023-8	BLACK	44.4	39.4	34.8	41.9	16	13	12.2	
42023-9	NTL.&BLK.	44.4	39.4	34.8	41.9	16	13	12.2	
42023-10	BLK.&NTL.	44.4	39.4	34.8	41.9	16	13	12.2	

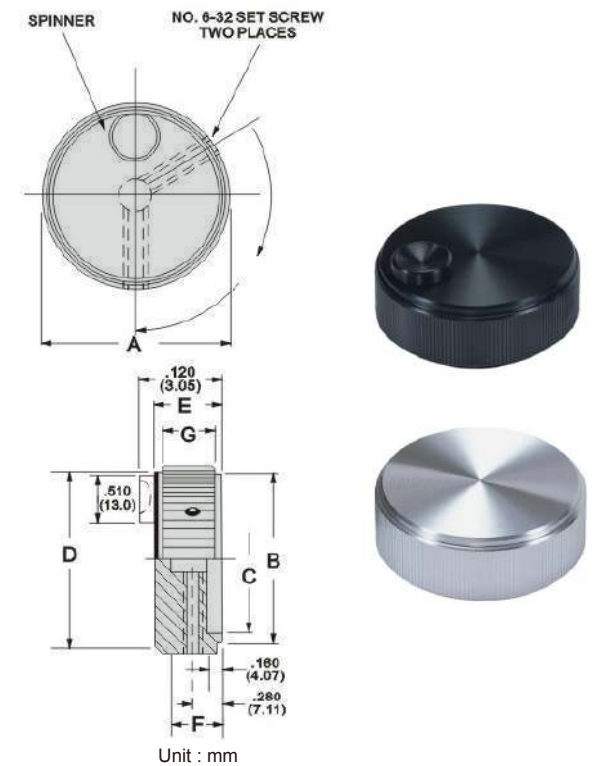

Description

- Material : Aluminum
- Straight knurl concentric set with indicator line

- 材質：鋁質
- 直齒狀
- 雙層旋鈕 + 指示線

PART NO.	COLOR	A	B	C	D	E	F	G
42024-1	NATURAL	19	12.7	14.5	17.8	16	29.2	7.11
42024-2	BLACK	19	12.7	14.5	17.8	16	29.2	7.11
42024-3	NATURAL	23.9	19	18	22.8	16	29.2	7.11
42024-4	BLACK	23.9	19	18	22.8	16	29.2	7.11

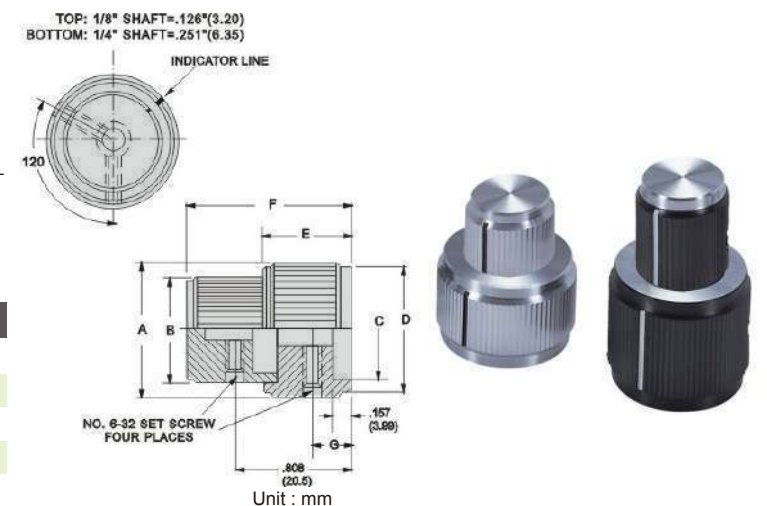

轉鈕

全鋁及鋁殼旋鈕

指示旋鈕

滑鈕

握把旋鈕

控制旋鈕

機械旋鈕

按鍵旋鈕

雙色旋鈕

DIY旋鈕

DIY旋鈕及配件

腳墊

轉鈕

全鋁及鋁殼旋鈕

指示旋鈕

滑鈕

握把旋鈕

控制旋鈕

機械旋鈕

按鍵旋鈕

雙色旋鈕

DIY旋鈕

DIY旋鈕及配件

腳墊

**Description**

- Material : Aluminum
- Straight knurl with crank spinner

- 材質：鋁質
- 直齒狀，加一個上旋鈕

PART NO.	COLOR	A	B	C	D	E	F	G
42025-1	NATURAL	44.4	39.4	34.8	41.9	16	13	12.2
42025-2	BLACK	44.4	39.4	34.8	41.9	16	13	12.2
42025-3	NTL.&BLK./BLK	44.4	39.4	34.8	41.9	16	13	12.2
42025-4	BLK.&NTL./BLK	44.4	39.4	34.8	41.9	16	13	12.2

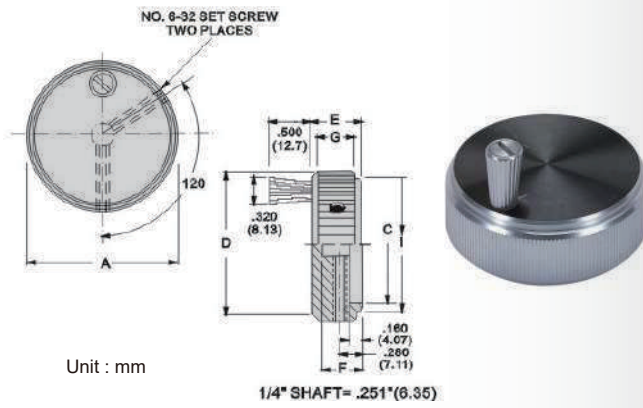

**Description**

- Material : Aluminum
- Straight knurl formed pointer and dot indicator

- 材質：鋁質
- 直齒狀，突出三角點及圓形指示點

PART NO.	COLOR	A	B	C	D	E	F	G	SHAF HOLE
42026-1	NATURAL	12.7	11.4	11	8.89	13.7	11.4	11.9	3.2
42026-2	NATURAL	12.7	11.4	11	8.89	13.7	11.4	11.9	6.4
42026-3	BLACK	12.7	11.4	11	8.89	13.7	11.4	11.9	3.2
42026-4	BLACK	12.7	11.4	11	8.89	13.7	11.4	11.9	6.4
42026-5	NATURAL	19	17.5	15.7	11.9	13.7	11.4	11.9	6.4
42026-6	BLACK	19	17.5	15.7	11.9	13.7	11.4	11.9	6.4
42026-7	NATURAL	23.9	22.3	20.8	14.5	13.7	11.4	11.9	6.4
42026-8	BLACK	23.9	23.3	20.8	14.5	13.7	11.4	11.9	6.4

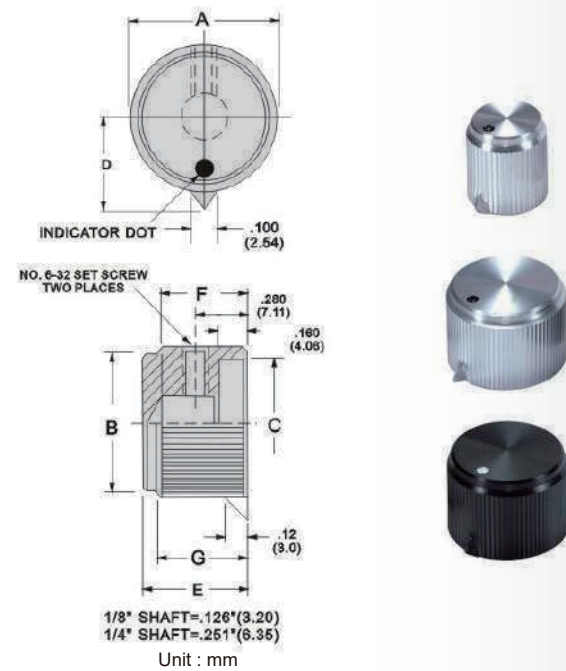

**Description**

- Material : Aluminum
- Straight knurl with pointer and indicator line

- 材質：鋁質
- 直齒狀，突出指示線

PART NO.	COLOR	A	B	C	D	E	F	G	SHAF HOLE
42028-1	NATURAL	12.7	11.4	9.65	11.4	9.4	5.08	8.89	3.2
42028-2	NATURAL	12.7	11.4	9.65	11.4	9.4	5.08	8.89	6.4
42028-3	BLACK	12.7	11.4	9.65	11.4	9.4	5.08	8.89	3.2
42028-4	BLACK	12.7	11.4	9.65	11.4	9.4	5.08	8.89	6.4
42028-5	NATURAL	19	17.8	15	17.8	13.2	6.09	9.9	6.4
42028-6	BLACK	19	17.8	15	17.8	13.2	6.09	9.9	6.4
42028-7	NATURAL	23.9	22.3	18	22.3	16	7	8.89	6.4
42028-8	BLACK	23.9	22.3	18	22.3	16	7	8.89	6.4

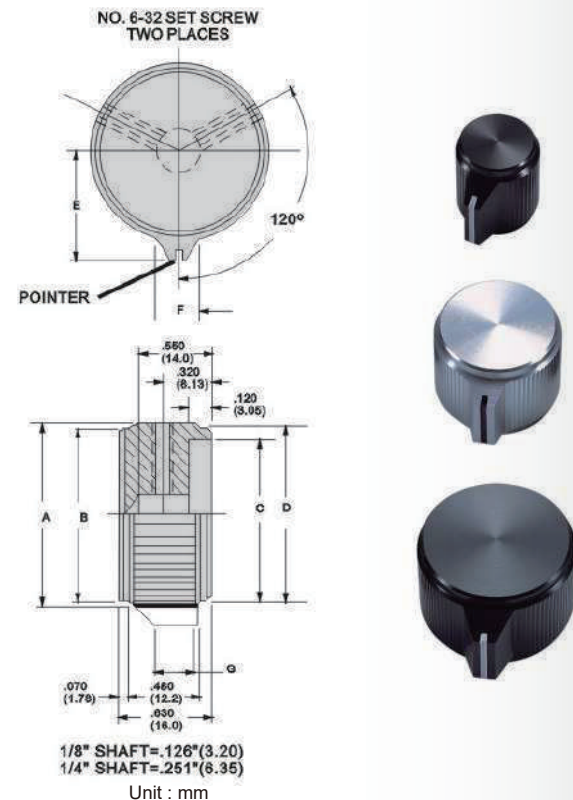

**Description**

- Material : Aluminum
- Straight knurl with arrow head indicator on skirt

- 材質：鋁質
- 直齒狀，銘板加三角形指示點

PART NO.	COLOR	A	B	C	D	E	F	G	SHAF HOLE
42029-1	NATURAL	12.7	11.4	9.65	19	16	13	10.9	3.2
42029-2	NATURAL	12.7	11.4	9.65	19	16	13	10.9	6.4
42029-3	BLACK	12.7	11.4	9.65	19	16	13	10.9	3.2
42029-4	BLACK	12.7	11.4	9.65	19	16	13	10.9	6.4
42029-5	NATURAL	19	17.8	14.9	28.3	16	13	10.9	6.4
42029-6	BLACK	19	17.8	14.9	28.3	16	13	10.9	6.4
BODY-TOP/SKIRT									
42029-7	BLK.&NTL.	12.7	11.4	9.65	19	16	13	10.9	3.2
42029-8	BLK.&NTL.	12.7	11.4	9.65	19	16	13	10.9	6.4
42029-9	BLK.&NTL.	19	17.8	14.9	28.3	16	13	10.9	3.2
42029-10	BLK.&NTL.	19	17.8	14.9	28.3	16	13	10.9	6.4

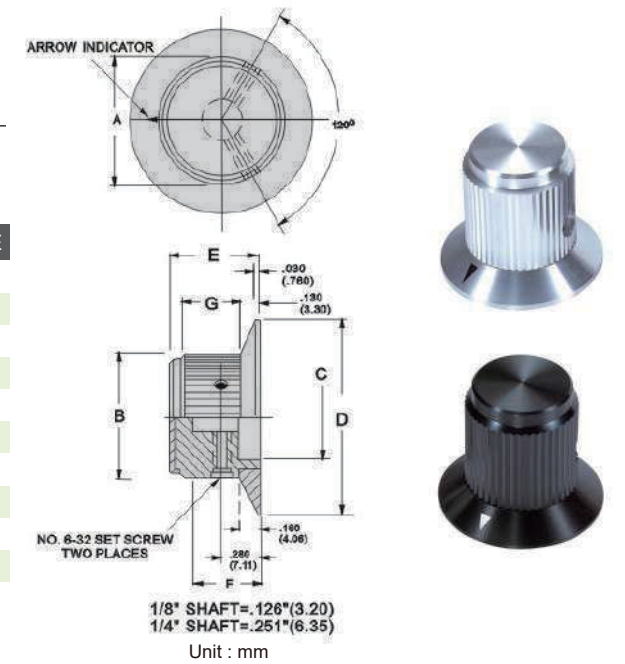

**Description**

- Material : Aluminum
- Push to turn with line indicator on skirt

- 材質：鋁質
- 彈壓可轉動下銘板

PART NO.	COLOR	A	B	C	D	E	F	G
42030-1	NATURAL	12.7	11.4	9.65	18.8	19	13	17
42030-2	BLACK	12.7	11.4	9.65	18.8	19	13	17
42030-3	NATURAL	19	17.3	14.9	28.3	19	13	17
42030-4	BLACK	19	17.3	14.9	28.3	19	13	17
42030-5	NATURAL	23.9	22.3	16.5	36.6	19	13	17
42030-6	BLACK	23.9	22.3	16.5	36.6	19	13	17

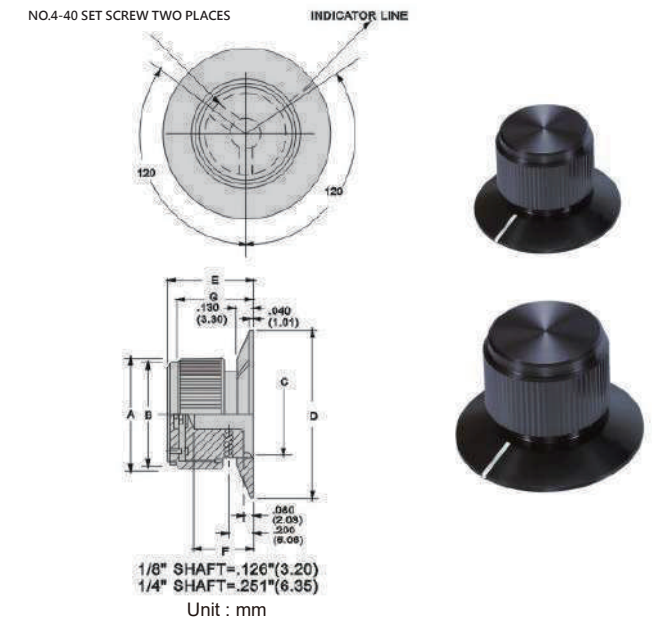

**Description**

- Material : Aluminum
- Knurl grip with top dot indicator

- 材質：鋁質
- 黑色環狀齒狀和指示點

PART NO.	COLOR	A	B	C	D	E	F	SHAF HOLE
42031-1	NTL.&BLK.	12.7	3.2	9.65	11.7	16	13	3.2
42031-2	NTL.&BLK.	12.7	6.4	9.65	11.7	16	13	6.4
42031-3	NTL.&BLK.	19	3.2	14.9	17.7	16	13	3.2
42031-4	NTL.&BLK.	19	6.4	14.9	17.7	16	13	6.4
42031-5	NTL.&BLK.	31.8	6.4	26.9	30.7	16	13	6.4

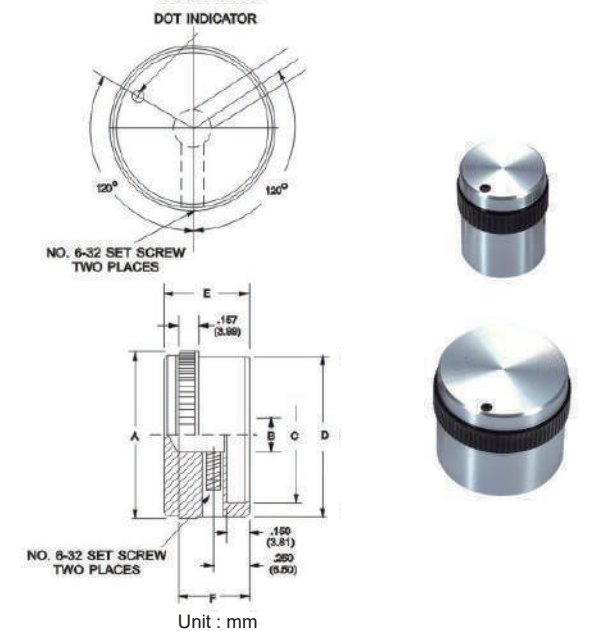

轉鈕  
turning knobs

全鋁及鋁殼旋鈕  
machined aluminum & shell knobs

指示旋鈕  
pointer knobs

滑鈕  
slide control knobs

握把旋鈕  
hand knobs

控制旋鈕  
control knobs

機械旋鈕  
fasten knobs

按鍵鈕  
push knobs

雙色旋鈕  
Double-shot knobs

DIV旋鈕及配件  
DIY control knobs & accessories

腳墊  
feet pad

轉鈕  
turning knobs

全鋁及鋁殼旋鈕  
machined aluminum & shell knobs

指示旋鈕  
pointer knobs

滑鈕  
slide control knobs

握把旋鈕  
hand knobs

控制旋鈕  
control knobs

機械旋鈕  
fasten knobs

按鍵鈕  
push knobs

雙色旋鈕  
Double-shot knobs

DIV旋鈕及配件  
DIY control knobs & accessories

腳墊  
feet pad



Description

- Material : Aluminum
- Knurl grip with top dot indicator

- 材質：鋁質
- 黑色環形齒狀和指示點

PART NO.	COLOR	A	B	C	D	E	F	SHAF HOLE
42032-1	NTL.& BLK.	12.7	11.7	9.65	19	16	16	3.2
42032-2	NTL.& BLK.	12.7	11.7	9.65	19	16	16	6.4
42032-3	NTL.& BLK.	19	18	16	28.7	16	16	6.4
42032-4	NTL.& BLK.	23.9	22.9	20	36.6	16	16	6.4

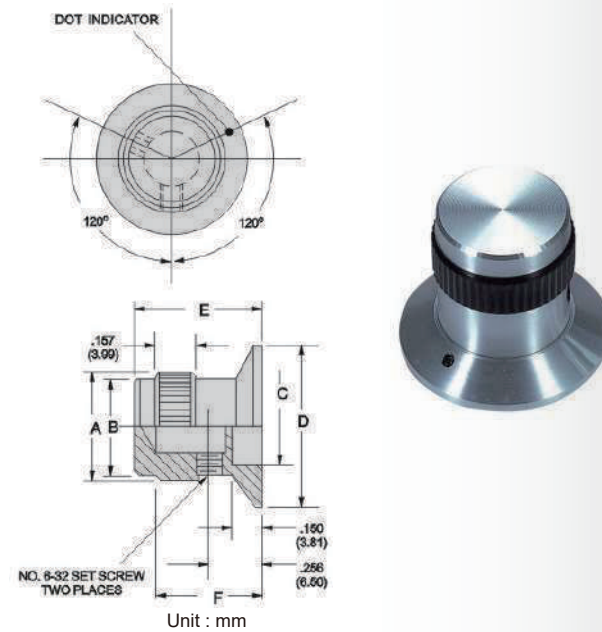

Description

- Material : Aluminum, matte finish
- Straight knurl with indicator on skirt

- 材質：鋁質，霧面
- 直齒狀，銘板加指示線

PART NO.	COLOR	A	B	C	D	E	F	G
42033-1	BLACK MATTE	9.7	7.1	6.5	12.7	2.54	11.9	15
42033-2	BLACK MATTE	12.7	9.7	6.4	16	4.09	12	16
42033-3	BLACK MATTE	15.7	9.7	9.7	25.4	4.09	16	20.6

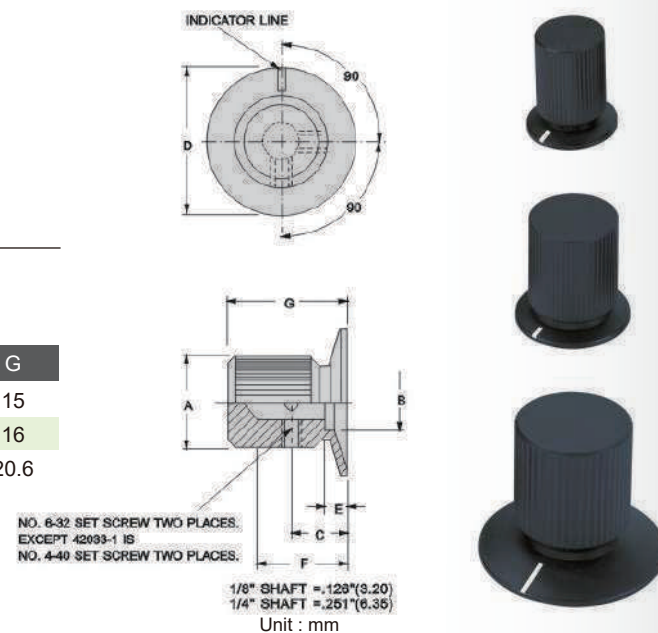

Description

- Material : Aluminum
- Straight knurl with indicator on skirt

- 材質：鋁質
- 直齒狀，側面加指示線

PART NO.	COLOR	A	B	C	D	E	F	G
42034-1	NATURAL	19.1	17.7	15	17.7	15.9	13	11.6
42034-2	BLACK	19.1	17.7	15	17.7	15.9	13	11.6
42034-3	NATURAL	24.1	22.7	17.7	22.7	15.9	13	11.6
42034-4	BLACK	24.1	22.7	17.7	22.7	15.9	13	11.6
42034-5	NTL-BLK.	19.1	17.7	11.5	17.7	15.9	13	11.6
42034-6	BLK-NTL.	19.1	17.7	11.5	17.7	15.9	13	11.6
42034-7	NTL-BLK.	24.1	22.7	17.7	22.7	15.9	13	11.6
42034-8	BLK-NTL.	24.1	22.7	17.7	22.7	15.9	13	11.6
42034-9	NATURAL	12.7	11.3	9.5	11.5	15.9	13	11.6
42034-10	BLACK	12.7	11.3	9.5	11.5	15.9	13	11.6

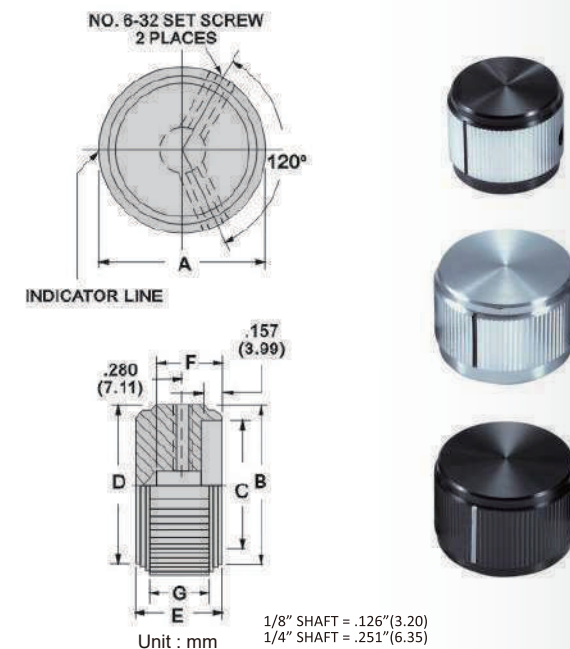

Description

- Aluminum Shell with plastic insert
- Shaft hole :  $\phi$  6 mm x 18 teeth
- Square serration with indicator line

- 材質：鋁質外殼加塑膠
- 插梢尺寸： $\phi$  6 mm  $\times$  18齒
- 方格紋路，指示線於頂部

PART NO.	COLOR	A	B	C	D	E	F	G
42035-1	NATURAL	15	14.4	10.9	14.4	16	14.5	11.5
42035-2	BLACK	15	14.4	10.9	14.4	16	14.5	11.5
42035-3	NATURAL	19.9	19.1	18	19.3	16.1	14	11.5
42035-4	BLACK	19.9	19.1	18	19.3	16.1	14	11.5
42035-5	NATURAL	25	24.2	20.9	24.3	16.1	14	11.5
42035-6	BLACK	25	24.2	20.9	24.3	16.1	14	11.5

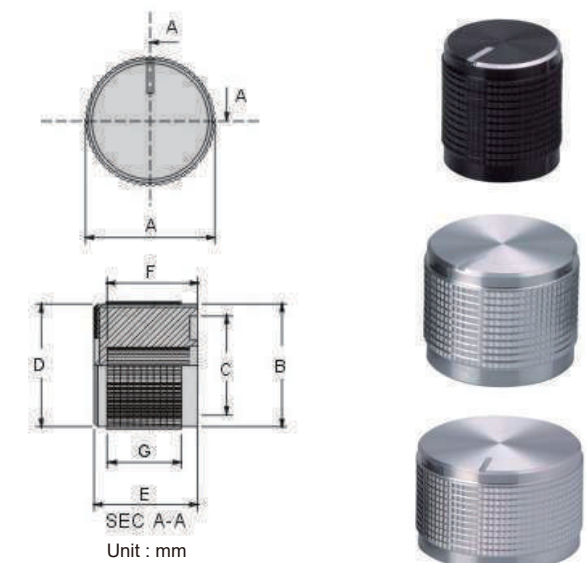

Description

- Aluminum Shell with plastic insert
- Shaft hole :  $\phi$  6 mm x 18 teeth
- Top & Side indicator line

- 材質：鋁質外殼加塑膠
- 插梢尺寸： $\phi$  6 mm  $\times$  18齒
- 指示線從頂部延伸至側邊

PART NO.	COLOR	A	B	C	D	E	F	G
42036-1	NATURAL	14.9	13.9	10.9	13.3	16.1	14	12.4
42036-2	BLACK	14.9	13.9	10.9	13.3	16.1	14	12.4
42036-3	NATURAL	19.8	18.7	15.9	18.2	16.1	14	12.4
42036-4	BLACK	19.8	18.7	15.9	18.2	16.1	14	12.4
42036-5	NATURAL	24.9	23.9	20.9	22.8	16.1	14	12.4
42036-6	BLACK	24.9	23.9	20.9	22.8	16.1	14	12.4

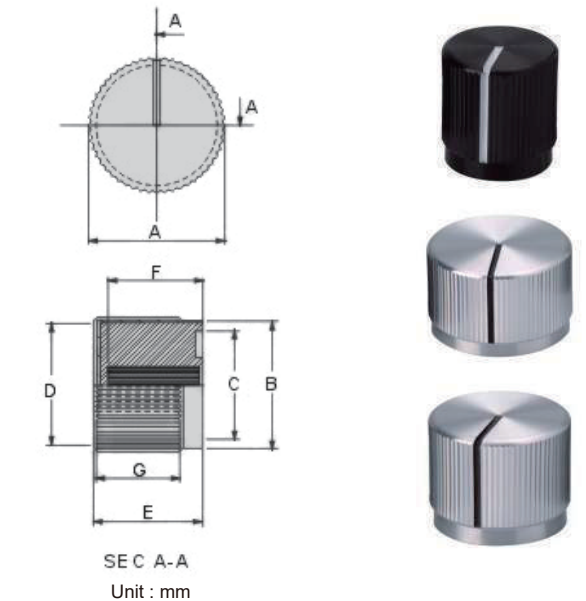

Description

- Aluminum Shell with plastic insert
- Shaft hole :  $\phi$  6 mm x 18 teeth
- Top inlay with indicator line

- 材質：鋁質外殼加塑膠
- 插梢尺寸： $\phi$  6 mm  $\times$  18齒
- 指示線於頂部

PART NO.	COLOR	A	B	C	D	E	F	G
42037-1	NATURAL	14.9	14.4	10.9	14.4	16.1	14	11.5
42037-2	BLACK	14.9	14.4	10.9	14.4	16.1	14	11.5
42037-3	NATURAL	19.9	19.1	15.9	19.3	16.1	14	11.5
42037-4	BLACK	19.9	19.1	15.9	19.3	16.1	14	11.5
42037-5	NATURAL	24.9	24.2	20.9	24.3	16.1	14	11.5
42037-6	BLACK	24.9	24.2	20.9	24.3	16.1	14	11.5

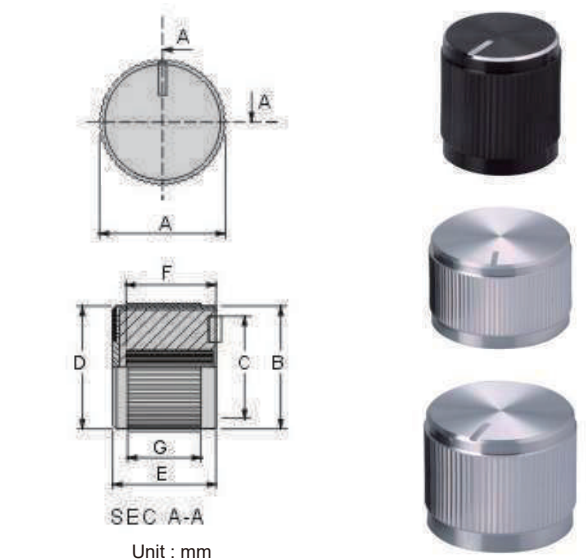



Description

- Material : PC
- With paint filled indicator line on triangular point
- With lateral screw fixing

- 材質：PC
- 三角點上劃漆
- 鎖螺絲於側邊

PART NO.	D	d1	d2	H	h1	h2	L1
43001-1	11.5	4	9.5	10.5	1.2	9	8.5
43001-2	20	6	16	15.5	13.5	13.5	13.5

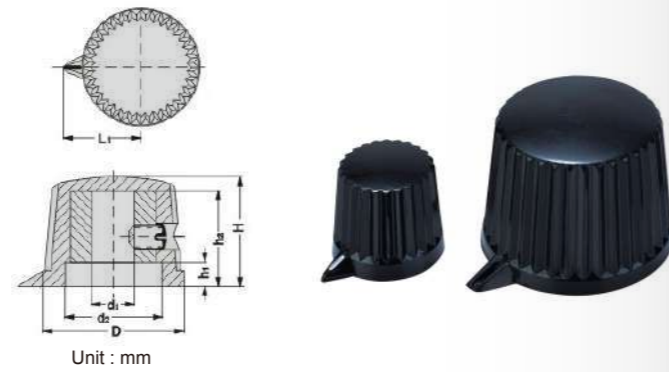

Unit : mm

Description

- Material : Black phenolic
- With paint filled indicator line on triangular point
- With lateral screw fixing

- 材質：黑色電木
- 三角點上劃漆
- 鎖螺絲於側邊

PART NO.	D	d1	d2	H	h1	h2	L1
43002-1	20	4	13.6	15.5	3.5	13.5	13.5
43002-2	20	6	13.6	15.5	3.5	13.5	13.5

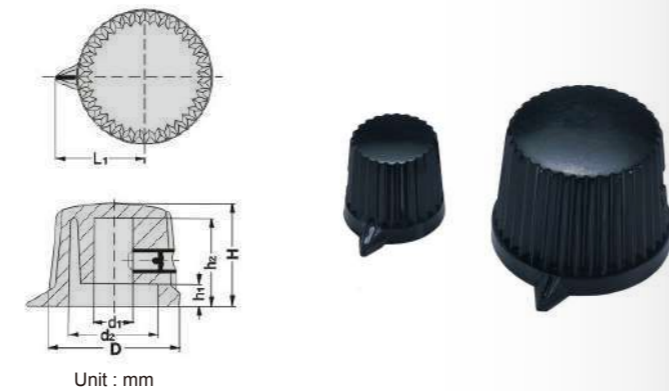

Unit : mm

Description

- Material : Black phenolic
- With lateral screw fixing and spun aluminum inlay
- With snapped-in indicator nose

- 材質：黑色電木
- 鎖螺絲，加鋁質上銘板
- 黏上突出三角點

PART NO.	D	d1	d2	H	h1	h2	L1	L2
43003-1	20	6	12	16	3.5	13	16	10
43003-2	24	6	15.5	16	3.5	13	18	12
43003-3	28	6	20.5	16	3.5	13	20	14

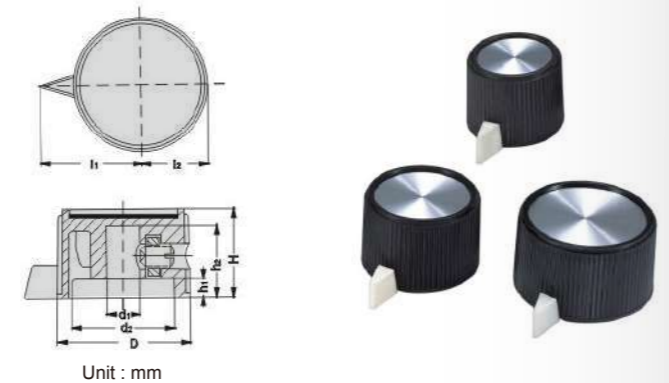

Unit : mm

Description

- Material : Phenolic
- Molded in brass stud assembled
- With ABS cap, screw and stud

- 材質：電木
- 埋銅
- ABS上蓋，鎖螺絲

PART NO.	D	d	H	h	L1	L2
43004-1	18.5	6	24	11.5	20	20
43004-2	21.5	6	26	11.5	30	30



Unit : mm

Description

- Material : ABS
- Steel ring with set screw

- 材質：ABS
- 螺絲加鐵圈

PART NO.	D	d1	d2	H	h1	h2	L1	L2
43005	21	6	17	19.5	6	18	13.5	10.5

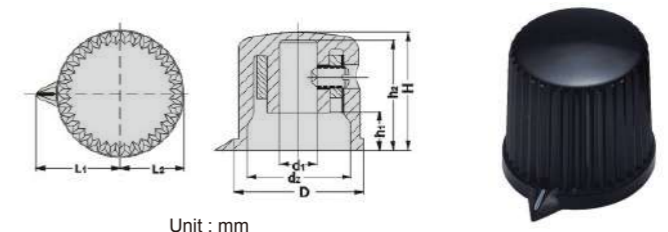

Unit : mm

Description

- Material : Phenolic
- Brass insert with set screw
- White epoxy painted indicator

- 材質：電木
- 埋銅，鎖螺絲
- 白色Epoxy劃漆指示線

PART NO.	D	d1	d2	H	h1	h2	L1	L2
43006	25	6	21	20	6	14	24	24

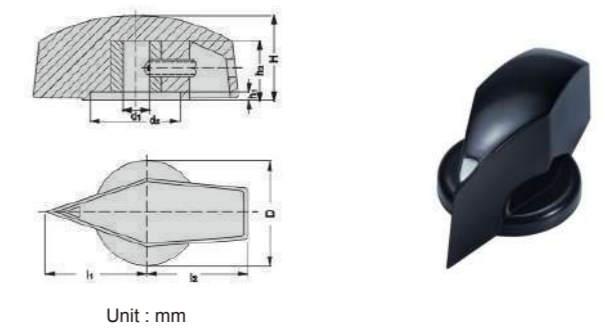

Unit : mm

Description

- Material : Phenolic
- Set screw
- White epoxy painted indicator

- 材質：電木
- 鎖螺絲
- 白色Epoxy劃漆指示線

PART NO.	D	d1	d2	H	h1	h2	L1	L2
43007	29	6	21.5	20	3.5	15	19	14

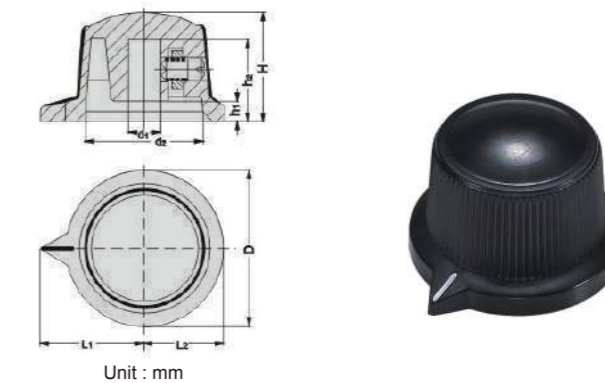

Unit : mm

Description

- Material : Phenolic
- Aluminum cap
- Steel ring with set screw

- 材質：電木
- 鋁質上蓋
- 螺絲加鐵圈

PART NO.	D	d1	d2	H	h1	h2	L
43009	20	6	16.5	18.8	3	16	13.5

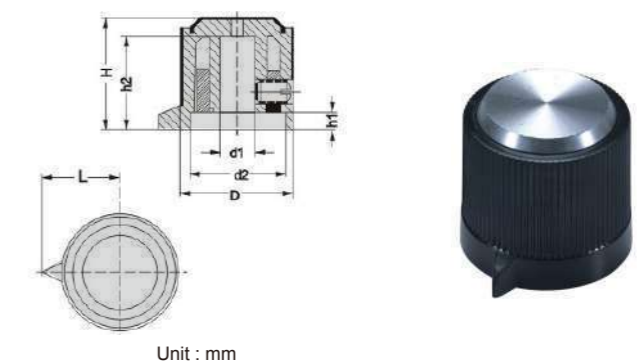

Unit : mm

Description

- Material : Phenolic
- Brass insert with set screw

- 材質：電木
- 埋銅，鎖螺絲

PART NO.	D	d1	d2	H	h1	h2	L1	L2
43012	31	6	21.5	20	6.5	17.5	20	15.5

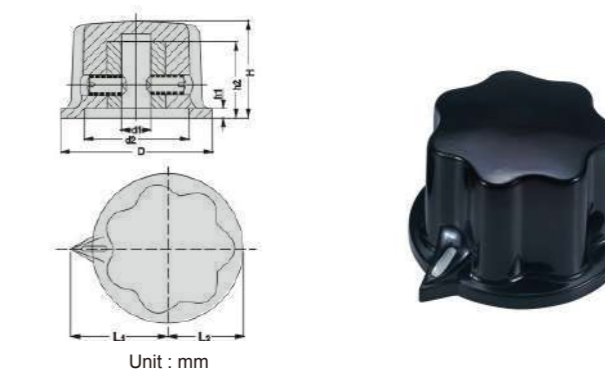

Unit : mm

轉鈕

全鋁及鋁殼旋鈕

指示旋鈕

滑鈕

握把旋鈕

控制旋鈕

機械旋鈕

按鍵旋鈕

雙色旋鈕

DIY旋鈕及配件

腳墊

轉鈕

全鋁及鋁殼旋鈕

指示旋鈕

滑鈕

握把旋鈕

控制旋鈕

機械旋鈕

按鍵旋鈕

雙色旋鈕

DIY旋鈕及配件

腳墊



轉鈕  
turning knobs

Description

- Material : Phenolic
- Epoxy paint filled indicator
- Brass insert with set screw

- 材質：電木
- Epoxy 劃漆指示線
- 埋銅，鎖螺絲

PART NO.	D	d1	H	h	L1	L2
43013	22	6	17	9	16	16

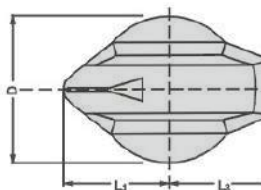
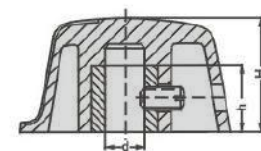

Unit : mm



全鋁及鋁殼旋鈕  
machined aluminum & shell knobs

指示旋鈕  
pointer knobs

Description

- Material : Phenolic
- With set screw

- 材質：電木
- 鎖螺絲

PART NO.	D	d1	d2	H	h1	h2	L1	L2
43014	18.5	6	16.5	13	2.7	10	11.5	11.5

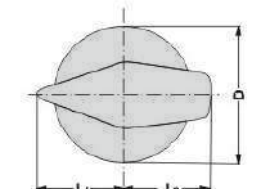
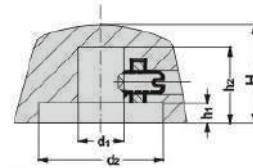

Unit : mm



滑鈕  
slide control knobs

握把旋鈕  
band knobs

Description

- Material : Phenolic
- Brass insert with set screw

- 材質：電木
- 埋銅，鎖螺絲

PART NO.	D	d1	d2	H	h1	h2	L1	L2
43015	20.6	6	14	18	3	12	19	20

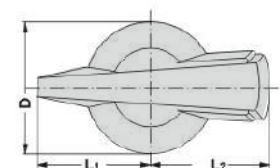
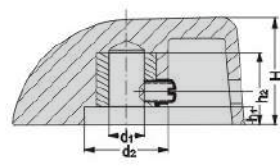

Unit : mm



控制旋鈕  
control knobs

機械旋鈕  
fasten knobs

按鍵旋鈕  
push knobs

Description

- Material : Phenolic
- Brass insert with set screw
- Epoxy paint filled indicator

- 材質：電木
- 埋銅，鎖螺絲
- Epoxy 劃漆指示線

PART NO.	D	d1	d2	H	h1	h2	L1	L2
43016-1	20	6	17	12.5	3	11	17	15
43016-2	23	6	20	16	3.5	12.5	21	19

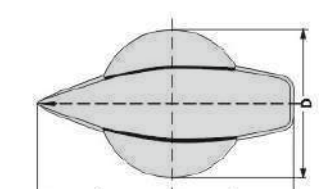
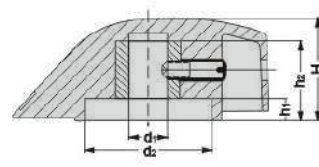

Unit : mm



雙色旋鈕  
Double-shot knobs

DIY旋鈕及配件  
DIY control knobs & accessories

腳墊  
feet pad

轉鈕  
turning knobs

全鋁及鋁殼旋鈕  
machined aluminum & shell knobs

指示旋鈕  
pointer knobs

滑鈕  
slide control knobs

握把旋鈕  
band knobs

控制旋鈕  
control knobs

機械旋鈕  
fasten knobs

按鍵旋鈕  
push knobs

雙色旋鈕  
Double-shot knobs

DIY旋鈕及配件  
DIY control knobs & accessories

腳墊  
feet pad

Description

- Material : Phenolic
- Set screw

- 材質：電木
- 鎖螺絲

PART NO.	D	d1	d2	H	h1	h2	L1	L2
43017	20	6	17	12.5	3	11	17	15

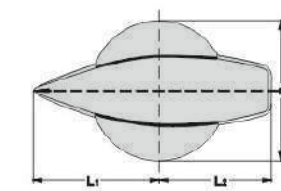
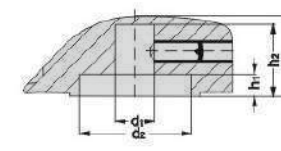

Unit : mm



Description

- Material : PC
- With set screw

- 材質：PC
- 鎖螺絲

PART NO.	D	d1	H	h1	h2	l1	l2
43018	15.4	6	13	1.5	10	10	11.7

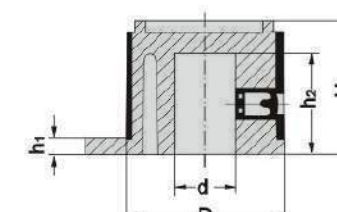
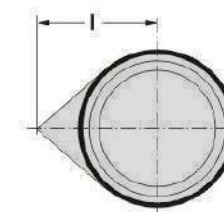

Unit : mm



Description

- Material : ABS
- With set screw

- 材質：ABS
- 鎖螺絲

PART NO.	D	d	H	h	l
43019	26	6	13	11	17.5

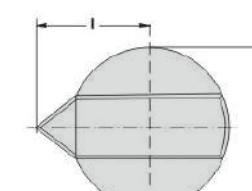
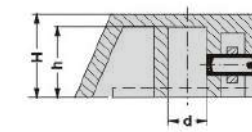

Unit : mm



Description

- Material : Black Phenolic
- With set screw

- 材質：黑色電木
- 鎖螺絲

PART NO.	L	d1	d2	H	h1	h2	L1	L2
43020	45	6	13	13	2.5	11	14	20

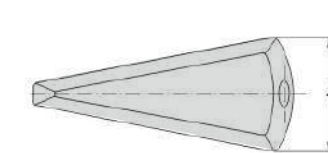
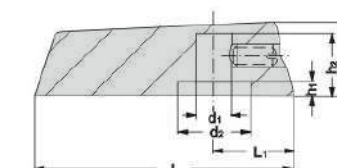

Unit : mm







Description

- Material : ABS
- Finish color : black
- Top with aluminum inlay

- 材質 : ABS
- 表面顏色 : 黑
- 鋁質上銘板

PART NO.	A	B	HOLE
43021-1	15.5	12.2	6.40 DIA
43021-3	26.67	16.3	3.20 DIA 6.40 DIA

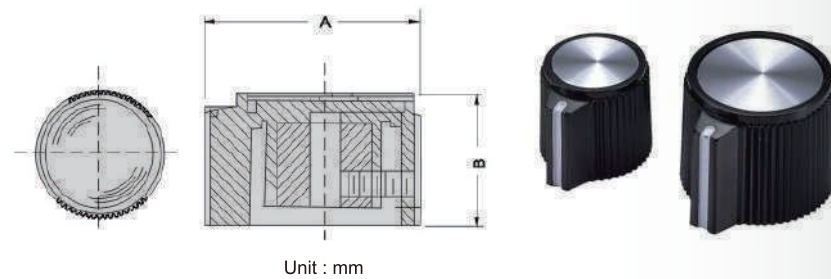

Description

- Material : Phenolic
- Epoxy paint filled indicator
- Brass insert with set screw

- 材質 : 電木
- 劃漆指示線
- 埋銅，鎖螺絲

PART NO.	D	d1	d2	d3	L	H	h1
43022	18	14.79	8.93	3.2	22.17	11.4	9.52

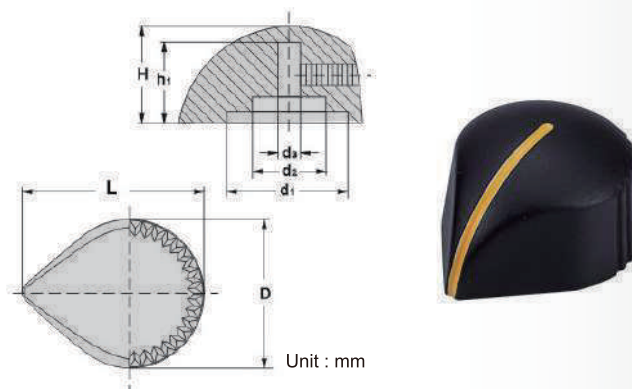

Description

- Material : Black Phenolic
- Finish : Gloss
- Shaft hole : D type  $\phi$  6 x 4.5 mm or 1/4" set screw type

- 材質 : 黑色電木
- 表面 : 亮面
- 插梢孔徑 : D型  $\phi$  6 x 4.5 mm 或 1/4" 鎖螺絲機種

PART NO.	D	d1	H	h1	l1
43024	16.9	6	10.5	8	11.4

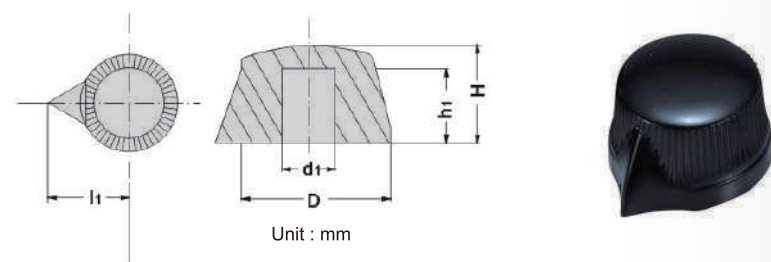

Description

- Material : Phenolic
- Straight knurl with aluminum spun plate
- With indicator line
- With No. 6-32 set screw

- 材質 : 電木
- 直齒狀，鋁質上銘板於頂部
- 指示線於側邊
- 鎖6-32號螺絲

PART NO.	A	B	C	D	E
43025-1	12.7	13.2	9	14.7	10.9
43025-2	15.9	13.4	11.8	19	11
43025-3	19.5	14.2	13.8	23.2	11.4

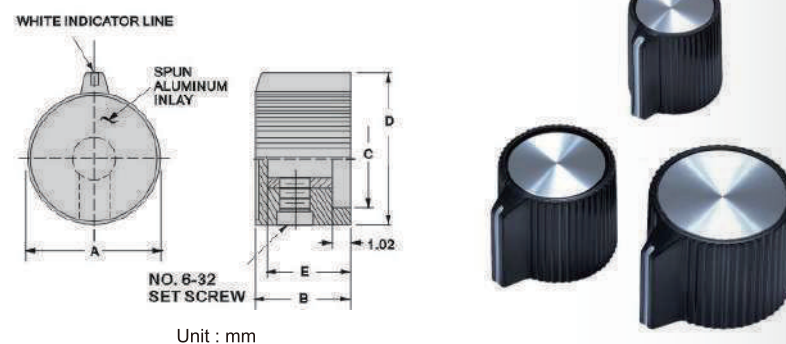

Description

- Material : Black phenolic
- Straight knurl with spun aluminum cap or spin plate

- 材質 : 黑色電木
- 直齒狀，鋁質上銘板或電鍍板

PART NO.	A	B	C	D	E
43027-1	12.7	14.24	9	14.8	10.6
43027-2	15.9	15	11.8	19.1	11.4
43027-3	19.3	15.6	13.8	23.1	11.4

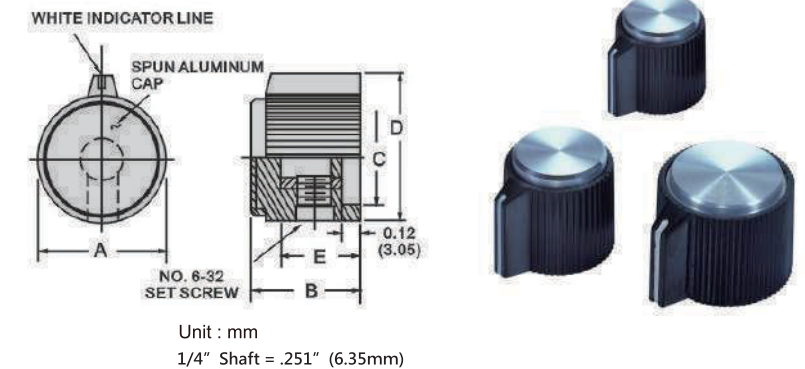

Description

- Material : Black phenolic
- With spun aluminum top inlay and ribbed with bar pointers and indicator line

- 材質 : 黑色電木
- 鋁質上銘板，突出指示點及指示線

PART NO.	A	B	C	D	E	F
43028-1	18.8	18.3	15	25	2.03	11.6
43028-2	21.8	21.6	17.8	32.5	2.3	11.6
43028-3	26.6	26.6	22.8	41.1	2.3	12.1

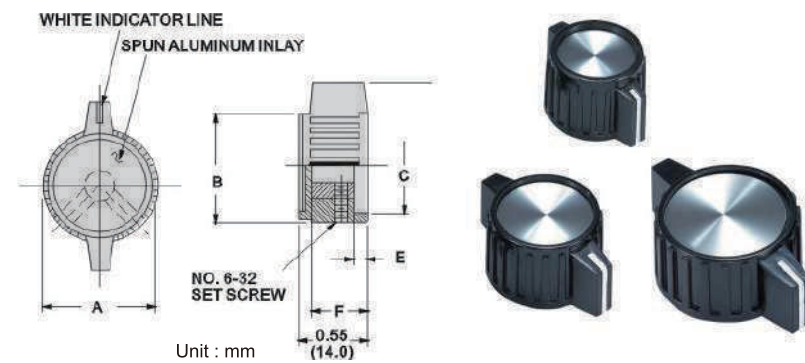

Description

- Material : ABS
- Finish : Gloss
- White indicator line on top
- Shaft hole :  $\phi$  6 mm x 18 teeth

- 材質 : ABS
- 表面 : 亮面
- 頂部白色指示線
- 插梢尺寸 :  $\phi$  6 mm X 18 齒

PART NO.	A	B	C
43029	15.2	12.7	19

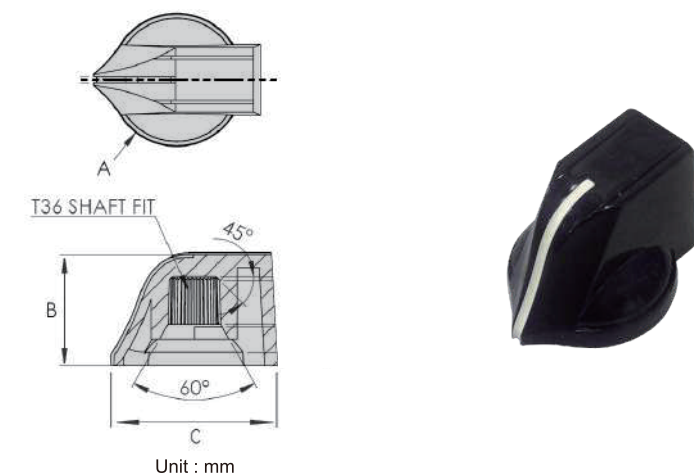

Description

- Material : Phenolic
- Finish : Gloss
- White indicator line on top
- Set screw
- Shaft hole :  $\phi$  6.0

- 材質 : 電木
- 表面 : 亮面
- 頂部白色指示線
- 鎖螺絲
- 插梢尺寸 :  $\phi$  6.0

PART NO.	A	B	C	D
43030	19.1	14.6	31.8	2.5

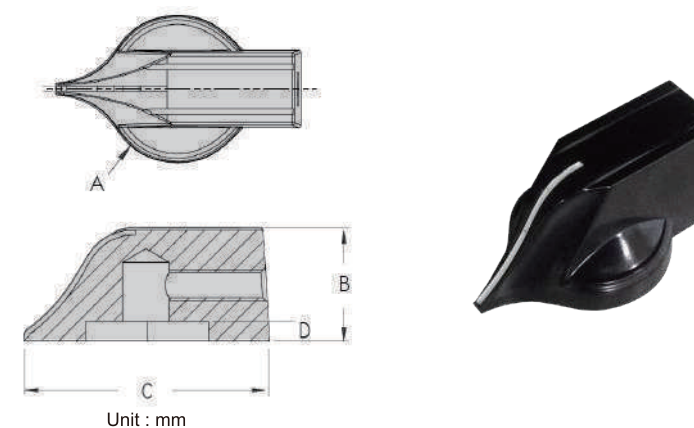

轉鈕

全鋁及鋁殼旋鈕

指示旋鈕

滑鈕

握把旋鈕

控制旋鈕

機械旋鈕

按鍵旋鈕

雙色旋鈕

DIY旋鈕及配件

腳墊

轉鈕

全鋁及鋁殼旋鈕

指示旋鈕

滑鈕

握把旋鈕

控制旋鈕

機械旋鈕

按鍵旋鈕

雙色旋鈕

DIY旋鈕及配件

腳墊



轉鈕  
全鋁及鋁殼旋鈕  
指示旋鈕  
滑鈕  
握把旋鈕  
控制旋鈕  
機械旋鈕  
按鍵  
雙色旋鈕  
DIY旋鈕及配件  
腳墊

**45001**  
Description

- Material : ABS
- Paint fill indicator line
- Color : Black, Green, Red, Chromed plated

- 材質 : ABS
- 劃漆指示線
- 顏色 : 黑、綠、紅或電鍍

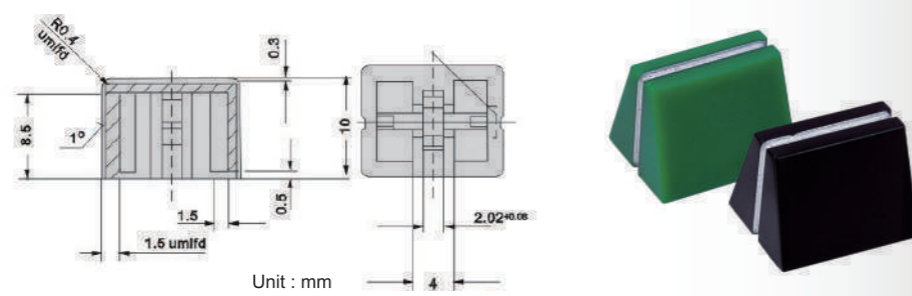

**45002**  
Description

- Material : ABS chrome plated
- Paint fill red indicator

- 材質 : ABS塑膠電鍍
- 劃漆指示線

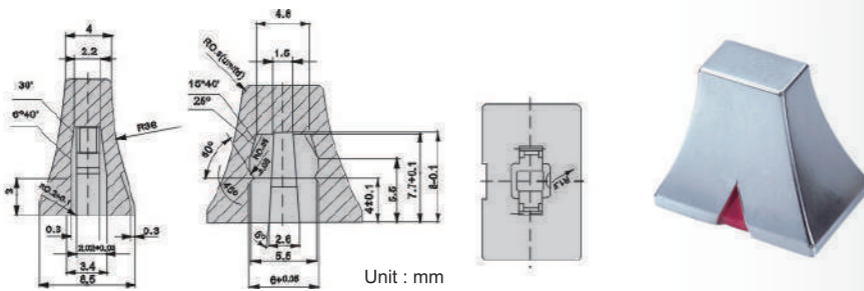

**45004**  
Description

- Material : ABS

- 材質 : ABS

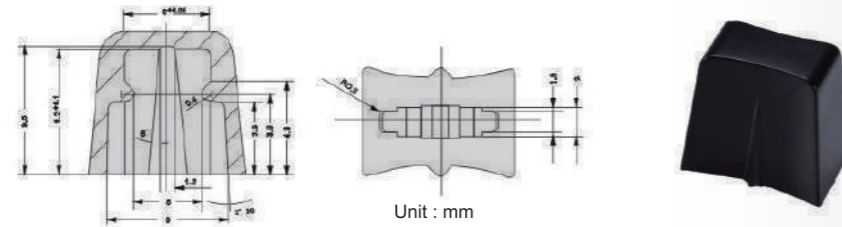

**45005**  
Description

- Material : ABS plastic with chrome plated

- 材質 : ABS塑膠電鍍

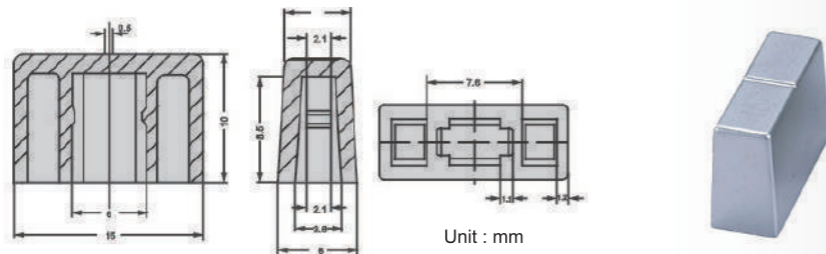

**45012**  
Description

- Material : ABS
- With paint filled indicator
- 25(L) x 15(W) x 9.6(H) mm
- Shaft hole : 3.5 x 1.1 mm

- 材質 : ABS
- 指示線劃漆
- 尺寸 : 25 (長) × 15 (寬) × 9.6 (高) mm
- 插梢孔徑 : 3.5 × 1.1 mm

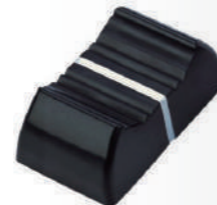

**45013**  
Description

- Material : ABS
- With paint filled indicator line
- 24.2(L) x 13(W) x 10.7(H) mm
- Shaft hole : 4 x 1 mm

- 材質 : ABS
- 指示線劃漆
- 尺寸 : 24.2 (長) × 13 (寬) × 10.7 (高) mm
- 插梢孔徑 : 4 × 1 mm



**45015**  
Description

- Material : ABS
- With paint filled indicator line, knurling on two sides, glossy finish
- 20.2(L) x 7.2(W) x 7.2(H) mm
- Shaft hole : 4.0 x 1.2 mm

- 材質 : ABS
- 亮面, 指示線劃漆, 兩側直齒狀
- 尺寸 : 20.2 (長) × 7.2 (寬) × 7.2 (高) mm
- 插梢孔徑 : 4.0 × 1.2 mm



**45016**  
Description

- Material : ABS
- Glossy finish with paint filled indicator line
- 14(L) x 9.7(W) x 10.4(H) mm
- Shaft hole : 4.2 x 1.1 mm

- 材質 : ABS
- 亮面, 指示線劃漆
- 尺寸 : 14 (長) × 9.7 (寬) × 10.4 (高) mm
- 插梢孔徑 : 4.2 × 1.1 mm



**45018**  
Description

- Material : ABS
- With paint filled indicator line
- 16.2(L) x 10.1(W) x 8(H) mm
- Shaft hole : 3.8 x 1.6 mm

- 材質 : ABS
- 指示線劃漆
- 尺寸 : 16.2 (長) × 10.1 (寬) × 8 (高) mm
- 插梢孔徑 : 3.8 × 1.6 mm



**45019**  
Description

- Material : ABS
- Light texture with paint filled indicator line
- 21(L) x 12.1(W) x 10.4(H) mm
- Shaft hole : 3.6 x 1.2 mm

- 材質 : ABS
- 細花表面, 指示線劃漆
- 尺寸 : 21 (長) × 12.1 (寬) × 10.4 (高) mm
- 插梢孔徑 : 3.6 × 1.2 mm



**45026**  
Description

- PP+TPR
- 25.8(L) x 11(W) x 10(H) mm
- Shaft hole : 4 x 12 mm

- PP + TPR, 咬花表面, 軟膠
- 尺寸 : 25.8 (長) × 11 (寬) × 10 (高) mm
- 插梢孔徑 : 4 × 1.2 mm



**46032**
**Description**

- Control knob with white indicator line
- Material : PBT
- Diameter : 47.7 mm Height : 26.2 mm



- 指示握把旋鈕，白色指示線
- 材質：PBT
- 外徑：47.7 mm 高度：26.2 mm

**46038**
**Description**

- Control knob with screen printing graphics
- Material : NYLON
- Diameter : 63 mm Height : 36 mm



- 控制握把旋鈕，曲印圖樣
- 材質：NYLON
- 外徑：63 mm 高度：36 mm

**46042**
**Description**

- Control Knob with printing graphics on the skirt, gloss finish
- Material : PHENOLIC
- Diameter : 51.8 mm Height : 27.2 mm
- Shaft hole : 1/4" D type with spring clip



- 控制握把旋鈕，下盤印刷圖樣，亮面
- 材質：電木
- 外徑：51.8 mm 高度：27.2 mm
- 插梢孔徑：1/4" D型，有彈片

**46117**
**Description**

- Plastic knob with paint filled indicator line on top and side, glossy finish, fluted grip
- Material : ABS
- Diameter : 27.3 mm Height : 15.5 mm
- Shaft hole : D type, 6 x 4.5 mm /  $\phi$  6 mm x 18 teeth



- 塑膠握把旋鈕，上方與側邊有指示線劃漆，亮面
- 材質：ABS
- 外徑：27.3 mm 高度：15.5 mm
- 插梢孔徑：D型，6 x 4.5 mm /  $\phi$  6 mm x 18齒

**46118**
**Description**

- Plastic knob with pad printing indicator line on top and side, glossy finish
- Material : ABS
- Diameter : 20.2 mm Height : 14.5 mm
- Shaft hole : D type, 6 x 4.5 mm / Screw type /  $\phi$  6 mm x 18 teeth



- 塑膠握把旋鈕，上方與側方有印刷指示線，亮面
- 材質：ABS
- 外徑：20.2 mm 高度：14.5 mm
- 插梢孔徑：D型，6 x 4.5 mm / 鎖螺絲機種 /  $\phi$  6 mm x 18齒

**46119**
**Description**

- Plastic knob with indicator line on top and side, matte texture finish
- Material : ABS
- Diameter : 24 mm Height : 12.7 mm
- Shaft hole :  $\phi$  6 mm x 36 teeth



- 塑膠握把旋鈕，上方與側邊有指示線，霧面
- 材質：ABS
- 外徑：24 mm 高度：12.7 mm
- 插梢孔徑： $\phi$  6 mm x 36齒

**46120**
**Description**

- Plastic knob, glossy finish, indicator line on top
- Material : ABS
- Diameter : 12 mm Height : 8 mm
- Shaft hole :  $\phi$  6 mm x 18 teeth



- 塑膠握把旋鈕，亮面，上方有指示線
- 材質：ABS
- 外徑：12 mm 高度：8 mm
- 插梢孔徑： $\phi$  6 mm x 18齒

**46121**
**Description**

- Plastic knob with paint filled indicator line, glossy finish
- Material : ABS
- Diameter : 20.3 mm Height : 13 mm
- Shaft hole :  $\phi$  6 mm x 18 teeth



- 塑膠握把旋鈕，指示線劃漆，亮面
- 材質：ABS
- 外徑：20.3 mm 高度：13 mm
- 插梢孔徑： $\phi$  6 mm x 18齒

**46140**
**Description**

- Plastic knob with texture finish, recess indicator line
- Material : ABS
- Diameter : 25.1 mm Height : 13.3 mm
- Shaft hole : D type, 6 x 4.5 mm



- 塑膠握把旋鈕，咬花面，凹槽指示線
- 材質：ABS
- 外徑：25.1 mm 高度：13.3 mm
- 插梢孔徑：D型，6 x 4.5 mm

**46082**
**Description**

- Control knob with line/ dot indicator, set screw fitting, available in two sizes
- Material : PHENOLIC
- Diameter : 19 mm, 23.8 mm
- Height : 11.7 mm, 14.5 mm

- 控制旋鈕，有指示點與指示線，鎖螺絲，有二種尺寸可選擇
- 材質：電木
- 外徑：19 mm、23.8 mm
- 高度：11.7 mm、14.5 mm

**46084**
**Description**

- Control knob with set screw
- Material : ABS
- Diameter : 20 mm Height : 16 mm

- 控制旋鈕，鎖螺絲
- 材質：ABS
- 外徑：20 mm 高度：16 mm

**46087**
**Description**

- Rotary knob with white square indicator on top, light texture finish
- Material : ABS
- Diameter : 23.8 mm Height : 20.1 mm
- Shaft hole :  $\phi$  6 mm x 18 teeth

- 旋轉控制旋鈕，上方有白色的方形指示點，淺咬花
- 材質：ABS
- 外徑：23.8 mm 高度：20.1 mm
- 插梢孔徑： $\phi$  6 mm  $\times$  18齒

**46088**
**Description**

- Control knob with set screw, indicator on top
- Material : ABS
- Diameter : 16.5 mm Height : 12.3 mm

- 控制旋鈕，鎖螺絲，頂部有指示線
- 材質：ABS
- 外徑：16.5 mm 高度：12.3 mm

**46089**
**Description**

- Knurled plastic knob assembled with aluminum top inlay, with calibrated graphics on skirt
- Material : ABS
- Diameter : 29.2 mm Height : 17.8 mm

- 塑膠控制旋鈕，直齒狀，鋁質上銘板，盤面可印刷刻度
- 材質：ABS
- 外徑：29.2 mm 高度：17.8 mm

**46090**
**Description**

- Fluted plastic knob with multi-colored plastic cap black indicator dot on top surface
- Material : ABS
- Diameter : 17 mm Height : 17.2 mm

- 塑膠控制旋鈕，上蓋可選擇多種顏色，黑色指示點於頂部
- 材質：ABS
- 外徑：17 mm 高度：17.2 mm

**46093**
**Description**

- Plastic knurled knob with or w/o aluminum cap
- Material : ABS
- Diameter : 14.9 mm Height : 14.5 mm

- 塑膠控制旋鈕，直齒狀，可加或不加上蓋銘板
- 材質：ABS
- 外徑：14.9 mm 高度：14.5 mm

**46095**
**Description**

- Rotary knob with recess indicator line on top, straight knurl in outside, light texture on top
- Material : ABS
- Diameter : 15 mm Height : 12 mm
- Shaft hole :  $\phi$  6 mm x 18 teeth

- 控制旋鈕，頂部淺咬花與凹槽指示線，外徑齒狀
- 材質：ABS
- 外徑：15 mm 高度：12 mm
- 插梢孔徑： $\phi$  6 mm  $\times$  18齒

**46102**
**Description**

- Plastic knob with indicator line on top, matte appearance finish, texture on the top knurling on the grip O.D.
- Material : ABS
- Diameter : 16.3 mm Height : 12.5 mm
- Shaft hole :  $\phi$  6 mm x 18 teeth

- 塑膠控制旋鈕，頂部有指示線與霧面咬花，外徑齒狀
- 材質：ABS
- 外徑：16.3 mm 高度：12.5 mm
- 插梢孔徑： $\phi$  6 mm  $\times$  18齒

**46103**
**Description**

- Plastic knob with paint filled indicator line on top, EDM texture finish
- Material : ABS
- Diameter : 19.8 mm Height : 16.9 mm
- Shaft hole :  $\phi$  6 mm x 18 teeth

- 塑膠控制旋鈕，頂部指示線劃漆，表面有放電紋路
- 材質：ABS
- 外徑：19.8 mm 高度：16.9 mm
- 插梢孔徑： $\phi$  6 mm  $\times$  18齒



轉  
turning knobs  
鈕

**46104**  
Description

- Plastic knob glossy finish on top, straight knurl and indicator line on top and side
- Material : ABS
- Diameter : 15.5 mm Height : 13.3 mm
- Shaft hole :  $\phi$  6 mm x 18 teeth

 全  
及  
鋁  
殼  
旋  
鈕  
machined aluminum & shell knobs

- 塑膠控制旋鈕，有指示線，側邊有直齒狀
- 材質：ABS
- 外徑：15.5 mm 高度：13.3 mm
- 插梢孔徑： $\phi$  6 mm  $\times$  18齒

 插  
示  
旋  
鈕  
pointer knobs

**46105**  
Description

- Aluminum shell knob with ABS plastic insert straight knurl and indicator line on top
- Material : Aluminum shell / ABS
- Diameter : 11 mm Height : 10 mm
- Shaft hole :  $\phi$  6 mm x 18 teeth

 滑  
鈕  
slide control knobs

- 鋁質外殼植入塑膠，直齒狀，頂部指示線
- 材質：鋁殼 / ABS
- 外徑：11 mm 高度：10 mm
- 插梢孔徑： $\phi$  6 mm  $\times$  18齒

 握  
把  
旋  
鈕  
band knobs

**46106**  
Description

- Fluted plastic knob light texture finish indicator dot on top
- Material : ABS
- Diameter : 14.8 mm Height : 14.8 mm
- Shaft hole :  $\phi$  6 mm x 18 teeth

 控  
制  
旋  
鈕  
control knobs

- 塑膠控制旋鈕，細咬花，指示點在頂部
- 材質：ABS
- 外徑：14.8 mm 高度：14.8 mm
- 插梢孔徑： $\phi$  6 mm  $\times$  18齒

 機  
械  
旋  
鈕  
fasten knobs

**46108**  
Description

- Aluminum shell knob with ABS plastic insert and indicator line on top, microbrite chamfer and silver ring
- Diameter : 13.3 mm Height : 12.2 mm
- Shaft hole :  $\phi$  6 mm x 18 teeth

 按  
鍵  
旋  
鈕  
push knobs

- 鋁質外殼植入塑膠，頂部有指示線，車削亮角與銀色環
- 外徑：13.3 mm 高度：12.2 mm
- 插梢孔徑： $\phi$  6 mm  $\times$  18齒

 雙  
色  
旋  
鈕  
two color knobs

**46109**  
Description

- Plastic knob, light texture finish
- Material : ABS
- Diameter : 29 mm Height : 15.4 mm
- Shaft hole :  $\phi$  6 mm x 18 teeth / D type 6 x 4.5 mm

 腳  
墊  
DIY control knobs & accessories

- 塑膠控制旋鈕，表面細咬花
- 材質：ABS
- 外徑：29 mm 高度：15.4 mm
- 插梢孔徑： $\phi$  6 mm  $\times$  18齒 / D型，6  $\times$  4.5 mm

 腳  
墊  
feet pad

**46110**  
Description

- Plastic knob with hair line polish on top with knurling and paint filled indicator line on top
- Material : ABS
- Diameter : 24.8 mm Height : 18.5 mm
- Shaft hole :  $\phi$  6 mm x 18 teeth



- 塑膠控制旋鈕，頂部髮絲紋，直齒狀，劃漆指示線
- 材質：ABS
- 外徑：24.8 mm 高度：18.5 mm
- 插梢孔徑： $\phi$  6 mm  $\times$  18齒

**46111**  
Description

- Plastic knob with knurl and hair line polish on top
- Material : ABS
- Diameter : 30 mm Height : 20.5 mm
- Shaft hole :  $\phi$  6 mm x 18 teeth



- 塑膠控制旋鈕，頂部髮絲紋，齒狀
- 材質：ABS
- 外徑：30 mm 高度：20.5 mm
- 插梢孔徑： $\phi$  6 mm  $\times$  18齒

**46115**  
Description

- Plastic knob with multi-color cap on top, light texture finish
- Material : ABS
- Diameter : 15.5 mm Height : 16.8 mm
- Shaft hole :  $\phi$  6 mm x 18 teeth



- 塑膠控制旋鈕，上蓋可選擇多種顏色，細咬花
- 材質：ABS
- 外徑：15.5 mm 高度：16.8 mm
- 插梢孔徑： $\phi$  6 mm  $\times$  18齒

**46116**  
Description

- Plastic knob with multi-color plastic cap, matte texture finish
- Material : ABS
- Diameter : 10.4 mm Height : 14.4 mm
- Shaft hole :  $\phi$  6 mm x 18 teeth



- 塑膠控制旋鈕，上蓋可選擇多種顏色，霧面
- 材質：ABS
- 外徑：10.4 mm 高度：14.4 mm
- 插梢孔徑： $\phi$  6 mm  $\times$  18齒

**46135**  
Description

- Rotary knob with light texture
- Material : ABS
- Diameter : 12.9 mm Height : 15 mm
- Shaft hole : D type 6 x 4.5 mm



- 旋轉控制旋鈕，細咬花
- 材質：ABS
- 外徑：12.9 mm 高度：15 mm
- 插梢孔徑：D型，6  $\times$  4.5 mm

 轉  
turning knobs  
鈕

 全  
及  
鋁  
殼  
旋  
鈕  
machined aluminum & shell knobs

 插  
示  
旋  
鈕  
pointer knobs

 滑  
鈕  
slide control knobs

 握  
把  
旋  
鈕  
band knobs

 控  
制  
旋  
鈕  
control knobs

 機  
械  
旋  
鈕  
fasten knobs

 按  
鍵  
旋  
鈕  
push knobs

 雙  
色  
旋  
鈕  
two color knobs

 腳  
墊  
DIY control knobs & accessories

 腳  
墊  
feet pad

轉  
turning knobs  
鈕

**46136**  
Description

- Fluted plastic knob with square indicator on top, gloss finish
- Material : ABS
- Diameter : 20 mm Height : 14.9 mm
- Shaft hole :  $\phi$  6mm x 18 teeth

 全  
machined aluminum & shell knobs  
及  
鋁  
殼  
旋  
鈕

- 塑膠控制旋鈕，頂部方型指示點，亮面
- 材質：ABS
- 外徑：20 mm 高度：14.9 mm
- 插梢孔徑： $\phi$  6 mm  $\times$  18齒

 指  
pointer knobs  
示  
旋  
鈕

**46143**  
Description

- Fluted plastic knob with indicator dot on top, gloss finish
- Material : ABS
- Diameter : 12.7 mm Height : 11.5 mm
- Shaft hole :  $\phi$  6 mm x 18 teeth

 滑  
slide control knobs  
鈕

- 塑膠控制旋鈕，頂部凹槽指示點，亮面
- 材質：ABS
- 外徑：12.7 mm 高度：11.5 mm
- 插梢孔徑： $\phi$  6 mm  $\times$  18齒

 握  
band knobs  
把  
旋  
鈕

**46144**  
Description

- Rotary knob with indicator dot on top, light texture finish
- Material : ABS
- Diameter : **11.9**mm Height : **14.3**mm
- Shaft hole :  $\phi$  6 mm x **36** teeth

 控  
control knobs  
制  
旋  
鈕

- 塑膠控制旋鈕，有指示點，細咬花
- 材質：ABS
- 外徑：**11.9** mm 高度：**14.3** mm
- 插梢孔徑： $\phi$  6 mm  $\times$  **36** 齒

 機  
fasten knobs  
械  
旋  
鈕

**46145**  
Description

- Rotary knob, straight knurl on outside, indicator on top
- Material : ABS
- Diameter : 4.2 mm Height : 23.7 mm
- Shaft hole : 6 x 4.5 mm

 按  
push knobs  
鍵  
旋  
鈕

- 塑膠控制旋鈕，指示線於頂部
- 材質：ABS
- 外徑：4.2 mm 高度：23.7 mm
- 插梢孔徑：6  $\times$  4.5 mm

 雙  
two color knobs  
色  
旋  
鈕

**46146**  
Description

- Rotary knob with straight knurl on outside, Al. inlay on top
- Material : ABS
- Diameter : 31.7 mm Height : 6.4 mm
- Shaft hole : 6 x 4.5 mm with spring insert

 DIY  
diy control knobs & accessories  
旋  
鈕  
及  
配  
件

- 旋轉控制旋鈕，外徑齒狀，鋁質上銘板
- 材質：ABS
- 外徑：31.7 mm 高度：6.4 mm
- 插梢孔徑：6  $\times$  4.5 mm，有彈片

 腳  
feet pad  
墊

**46147**  
Description

- Fluted plastic knob light texture finish indicator dot on top
- Material : ABS
- Diameter : 20 mm Height : 18 mm
- Shaft hole :  $\phi$  6 mm x 18 teeth

 轉  
turning knobs  
鈕

 全  
machined aluminum & shell knobs  
及  
鋁  
殼  
旋  
鈕

- 塑膠控制旋鈕，細咬花，頂部有指示點
- 材質：ABS
- 外徑：20 mm 高度：18 mm
- 插梢孔徑： $\phi$  6 mm  $\times$  18齒

 指  
pointer knobs  
示  
旋  
鈕

**46148**  
Description

- Fluted plastic knob light texture finish indicator dot on top
- Material : ABS
- Diameter : 24 mm Height : 15.9 mm
- Shaft hole :  $\phi$  6 mm x 18 teeth

 滑  
slide control knobs  
鈕

- 塑膠控制旋鈕，細咬花，頂部有指示點
- 材質：ABS
- 外徑：24 mm 高度：15.9 mm
- 插梢孔徑： $\phi$  6 mm  $\times$  18齒

 握  
band knobs  
把  
旋  
鈕

**46152**  
Description

- Fluted plastic knob light texture finish indicator dot on top
- Material : ABS
- Diameter : 17.8 mm Height : **15.6** mm
- Shaft hole :  $\phi$  6 mm x **36** teeth

 控  
control knobs  
制  
旋  
鈕

- 塑膠控制旋鈕，表面細咬花，頂部有指示線
- 材質：ABS
- 外徑：17.8 mm 高度：**15.6** mm
- 插梢孔徑： $\phi$  6 mm  $\times$  **36** 齒

 機  
fasten knobs  
械  
旋  
鈕

**46159**  
Description

- Fluted plastic knob light texture finish with indicator dot on top
- Material : ABS
- Diameter : 23 mm Height : 14 mm
- Shaft hole :  $\phi$  6 mm x 18 teeth / D type  $\phi$  6 x 4.5 mm

 按  
push knobs  
鍵  
旋  
鈕

- 塑膠控制旋鈕，細咬花，頂部有指示點
- 材質：ABS
- 外徑：23 mm 高度：14 mm
- 插梢孔徑： $\phi$  6 mm  $\times$  18齒 / D型， $\phi$  6  $\times$  4.5 mm

 雙  
two color knobs  
色  
旋  
鈕

**46162**  
Description

- Material : ABS
- Finish : Gloss
- White indicator line on top
- Diameter : 12.6 mm Height : 15.7 mm
- Shaft hole :  $\phi$  6.4 /  $\phi$  6 mm x 18 teeth

 DIY  
diy control knobs & accessories  
旋  
鈕  
及  
配  
件

- 材質：ABS
- 表面：亮面
- 頂部白色指示線
- 外徑：12.6 mm 高度：15.7 mm
- 插梢孔徑： $\phi$  6.4 /  $\phi$  6 mm  $\times$  18齒

PART NO.	SHAFT HOLE
46162-1	6.4
46162-2	6 X18 teeth

 Custom color is available.  
可客製化顏色

轉  
turning knobs  
鈕

**46163**  
Description

- Material : Phenolic
- Finish : Gloss
- White indicator line on top
- Diameter : 38 mm    Height : 19.1 mm
- Shaft hole :  $\phi$  6.55 mm

- 材質：電木
- 表面：亮面
- 頂部白色指示線
- 外徑：38 mm    高度：19.1 mm
- 插梢尺寸： $\phi$  6.55 mm

 指示  
pointer knobs  
旋鈕

**46164**  
Description

- Material : ABS
- Finish : Gloss
- White indicator line on top & side
- Diameter : 38 mm    Height : 19.5 mm
- Shaft hole :  $\phi$  6 mm x 18 teeth

- 材質：電木 或 ABS
- 表面：亮面
- 頂部與側邊白色指示線
- 外徑：38 mm    高度：19.5 mm
- 插梢尺寸： $\phi$  6 mm X 18齒

 滑  
slide control knobs  
鈕

**46165**  
Description

- Material : ABS
- Finish : light texture
- White indicator line on top & side
- Diameter : 12.2 mm    Height : 14.8 mm
- Shaft hole :  $\phi$  6 mm X 18 teeth

- 材質：ABS
- 表面：細咬花面
- 頂部與側邊白色指示線
- 外徑：12.2 mm    高度：14.8 mm
- 插梢尺寸： $\phi$  6 mm X 18齒

 握把  
band knobs  
旋鈕

 控制  
control knobs  
旋鈕

 機械  
fasten knobs  
旋鈕

 按鍵  
push knobs  
鈕

 雙色  
Double-shot knobs  
旋鈕

 DIY  
DIY control knobs & accessories  
旋鈕及配件

 腳  
feet pad  
墊

**47004**  
Description

- Mechanical knob with female brass insert or steel stud
- Material : PHENOLIC
- Diameter : 46 mm
- Height : 27 mm

- 機械旋鈕，埋入螺母或螺絲
- 材質：電木
- 外徑：46 mm
- 高度：27 mm

**47012**  
Description

- Mechanical knob with molded-in steel stud.
- Steel stud available in various sizes per customer requirement
- Material : ABS
- Diameter : 27.9 mm
- Height : 10.7 mm

- 機械旋鈕，埋入螺絲，螺絲規格可客製化
- 材質：ABS
- 外徑：27.9 mm
- 高度：10.7 mm

**47013**  
Description

- 2 shot Mechanical knob with molded-in steel stud.
- Steel stud available in various sizes per customer requirement
- Material : TPR+ABS
- Diameter : 40 mm
- Height : 23 mm

- 雙色機械旋鈕，埋入螺絲，螺絲規格可客製化
- 材質：TPR + ABS
- 外徑：40 mm
- 高度：23 mm

 轉  
turning knobs  
鈕

 全  
machined aluminum & shell knobs  
鋁及殼旋鈕

 指示  
pointer knobs  
旋鈕

 滑  
slide control knobs  
鈕

 握把  
band knobs  
旋鈕

 控制  
control knobs  
旋鈕

 機械  
fasten knobs  
旋鈕

 按鍵  
push knobs  
鈕

 雙色  
Double-shot knobs  
旋鈕

 DIY  
DIY control knobs & accessories  
旋鈕及配件

 腳  
feet pad  
墊



Description

- Material : ABS
- Shaft hole : 3.3 x 3.3 mm

- 材質 : ABS
- 插梢尺寸 : 3.3 × 3.3 mm

PART NO.	DIA	HEIGHT	FINISH	SOLE
48001-2	6	7.5	TEXTURE	2.8×2.8
48001-5	8.8	10.7	GLOSSY	3.3×3.3
48001-8	10	15.2	GLOSSY	3.3×3.3
48001-10	7.6	13.8	GLOSSY	3.3×3.3



Description

- Material : ABS with aluminum shell
- Shaft hole : 3.3 x 3.3 mm

- 材質 : ABS + 鋁殼
- 插梢尺寸 : 3.3 × 3.3 mm

PART NO.	DIA	HEIGHT	FINISH
48002-1	8.5	14.5	NATURAL
48002-2	8.5	14.5	BLACK
48002-3	9	13.5	NATURAL
48002-4	9	13.5	BLACK
48002-5	10.5	16	NATURAL
48002-6	10.5	16	BLACK



Description

- Material : ABS
- Shaft hole : 3.3 x 3.3 mm

- 材質 : ABS
- 插梢尺寸 : 3.3 × 3.3 mm

PART NO.	L	W	H
48003-1	6	6	8.2
48003-2	8	8	5.2
48003-4	15	7.2	10.6
48003-5	15.3	6.3	12
48003-6	18.2	7.8	13.7
48003-7	6	6	7.5



49001 Description

- Material : PP+TPR
- With raise indicator line
- Diameter : 16 mm Height : 14.8 mm
- Shaft hole : D type, 6 x 4.5 mm 6 mm x 18 teeth

- 材質 : PP + TPR
- 表面 : 軟膠咬花，大直齒
- 突出指示線
- 外徑 : 16 mm 高度 : 14.8 mm
- 插梢孔徑 : D型，6 × 4.5 mm 6 mm × 18齒

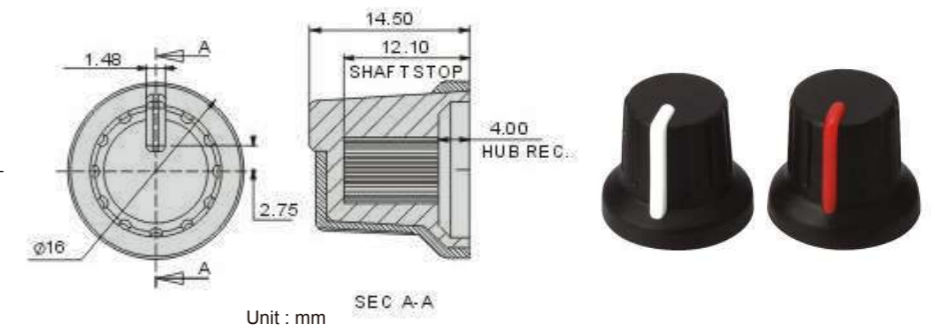

49002 Description

- Material : PP+TPR
- Finish : Texture soft touch surface
- Aluminum inlay on top
- Diameter : 13 mm Height : 12 mm
- Shaft hole : 6 x 4.5 mm with spring insert

- 材質 : PP + TPR
- 表面 : 軟膠咬花面，鋁質上銘板，大直齒
- 外徑 : 13 mm 高度 : 12 mm
- 插梢孔徑 : D型，6 × 4.5 mm，壓彈片

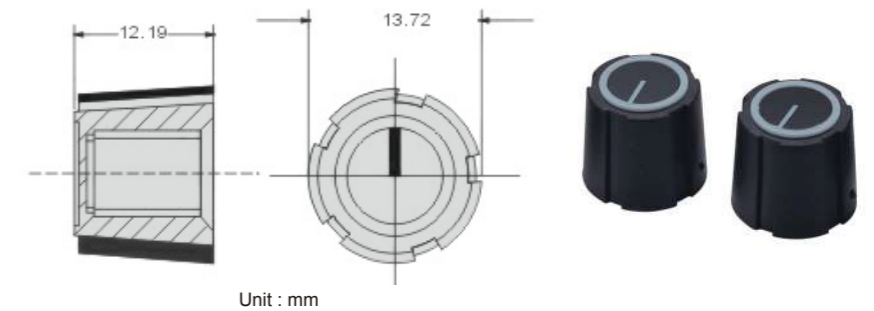

49003 Description

- Material : PP+TPR
- Finish : Texture soft touch knob one set screw on side
- Diameter : 29 mm Height : 14 mm
- Shaft hole : set screw type with 6 mm or 1/4" metal insert

- 材質 : PP + TPR
- 表面 : 軟膠咬花面，大直齒
- 外徑 : 29 mm 高度 : 14 mm
- 插梢孔徑 : 埋入金屬件 6 mm或1/4"

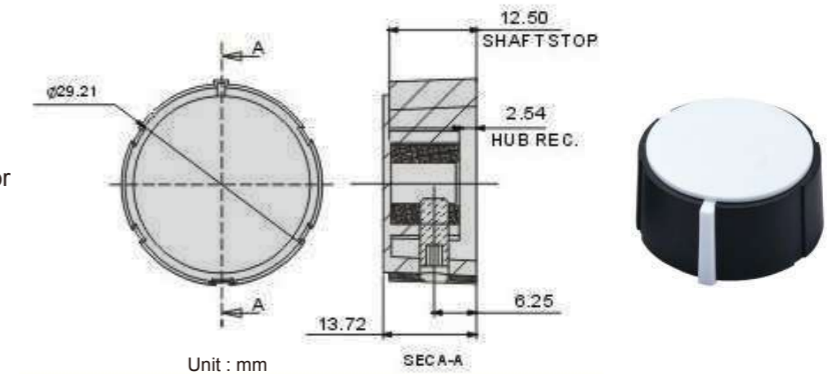

49004 Description

- Material : PP+TPR
- Finish : Texture soft touch surface aluminum inlay on top
- Diameter : 18.5 mm Height : 18 mm
- Shaft hole : D type 6 x 4.5 mm with spring insert or 6 mm x 18 teeth

- 材質 : PP + TPR
- 表面 : 軟膠咬花面，鋁質上銘板，大直齒
- 外徑 : 18.5 mm 高度 : 18 mm
- 插梢孔徑 : D型，6 × 4.5 mm 6 mm × 18齒

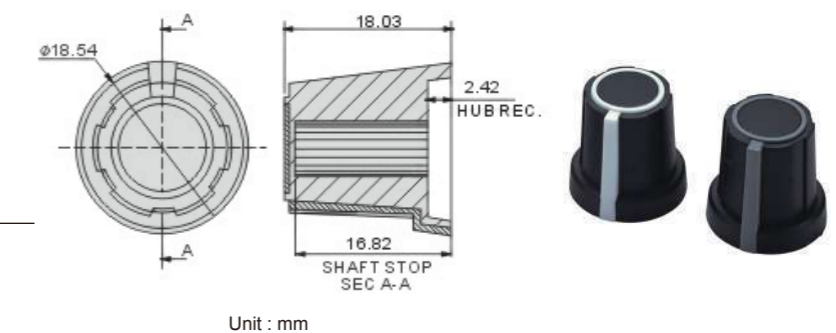

轉鈕  
全鋁及鋁殼旋鈕  
指示旋鈕  
滑鈕  
握把旋鈕  
控制旋鈕  
機械旋鈕  
按鍵鈕  
雙色旋鈕  
DIY旋鈕及配件  
腳墊

轉鈕  
全鋁及鋁殼旋鈕  
指示旋鈕  
滑鈕  
握把旋鈕  
控制旋鈕  
機械旋鈕  
按鍵鈕  
雙色旋鈕  
DIY旋鈕及配件  
腳墊



**49005**  
Description

- Dual Knob : Soft touch surface
- Material : PP+TPR
- Finish : Light texture
- Shaft hole : D type, 2.5 x 3.4 mm

- 雙層旋鈕，軟膠表面
- 材質：PP + TPR
- 表面：軟膠細咬花
- 插梢孔徑：D型，2.5 × 3.4 mm

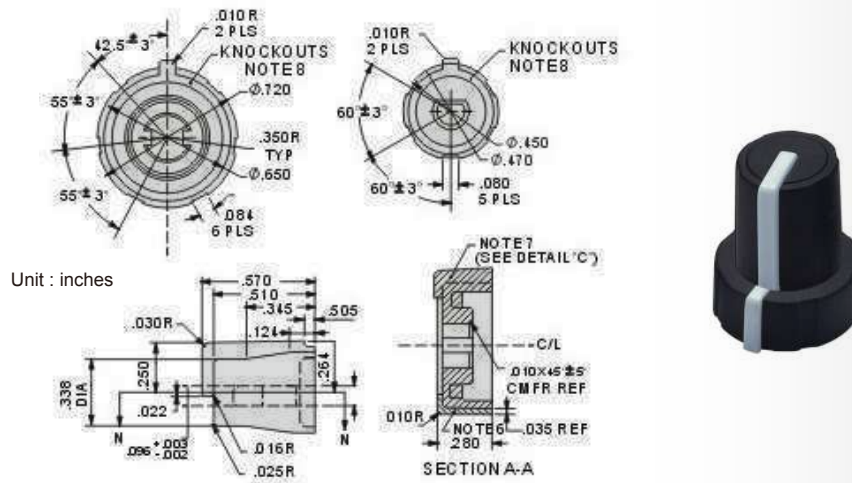

**49006**  
Description

- Material : PP+TPR
- Finish : Light texture soft touch knob
- Diameter : 12 mm Height : 15 mm
- Shaft hole : D type, 6 x 4.5 mm

- 材質：PP + TPR
- 表面：軟膠細咬花
- 外徑：12 mm 高度：15 mm
- 插梢孔徑：D型，6 × 4.5 mm

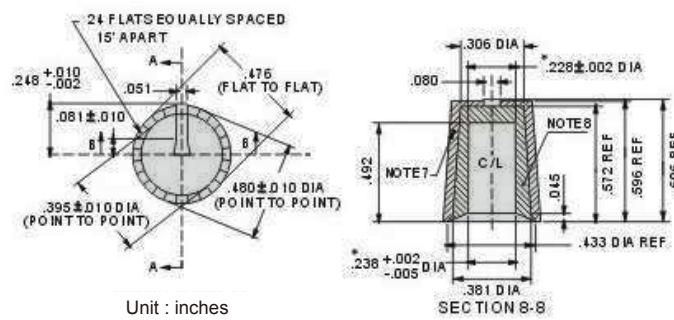

**49007**  
Description

- Material : PP+TPR
- Finish : Light texture soft touch knob
- Diameter : 16 mm Height : 11 mm
- Shaft hole : D type, 6 x 4.5 mm

- 材質：PP + TPR
- 表面：軟膠細咬花
- 外徑：16 mm 高度：11 mm
- 插梢孔徑：D型，6 × 4.5 mm

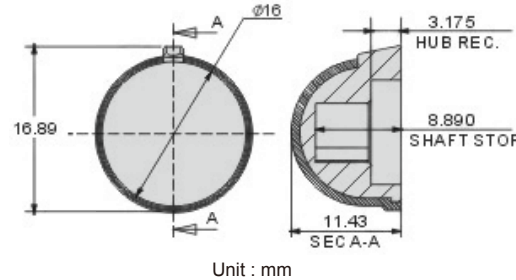

**49008**  
Description

- Material : PP+TPR
- Finish : Texture soft touch surface
- Diameter : 17.1 mm Height : 17.5 mm
- Shaft hole : D type, 6 x 4.5 mm with spring clip

- 材質：PP + TPR
- 表面：軟膠咬花面，大直齒
- 外徑：17.1 mm 高度：17.5 mm
- 插梢孔徑：D型，6 × 4.5 mm 壓彈片

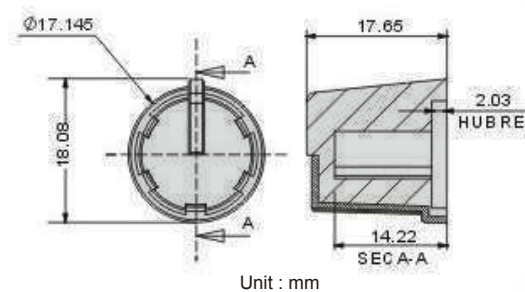

**49009**  
Description

- Material : PP+TPR
- Finish : Light texture soft touch knob
- Diameter : 18.8 mm Height : 15.4 mm
- Shaft hole : 6 mm x 18 teeth

- 材質：PP + TPR
- 表面：軟膠咬花面，大直齒
- 外徑：18.8 mm 高度：15.4 mm
- 插梢孔徑：6 mm × 18齒

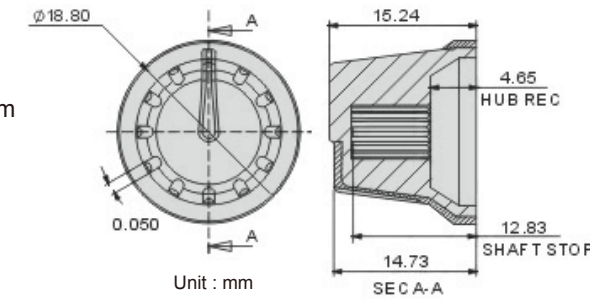

**49010**  
Description

- Material : PP+TPR
- Finish : Light texture soft touch knob
- Diameter : 14.4 mm Height : 14.8 mm
- Shaft hole : D type 6 x 4.5 mm or 6 mm x 18 teeth

- 材質：PP + TPR
- 表面：軟膠咬花面，大直齒
- 外徑：14.4 mm 高度：14.8 mm
- 插梢孔徑：D型，6 × 4.5 mm 6 mm × 18齒

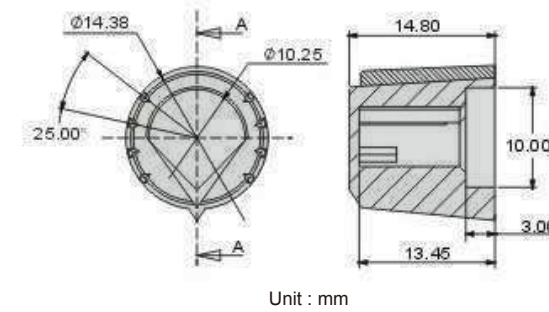

**49013**  
Description

- Material : PP+TPR
- Finish : Light texture
- Shaft hole : D type, 6 x 4.5 mm

- 材質：PP + TPR
- 表面：軟膠咬花面
- 插梢孔徑：D型，6 × 4.5 mm

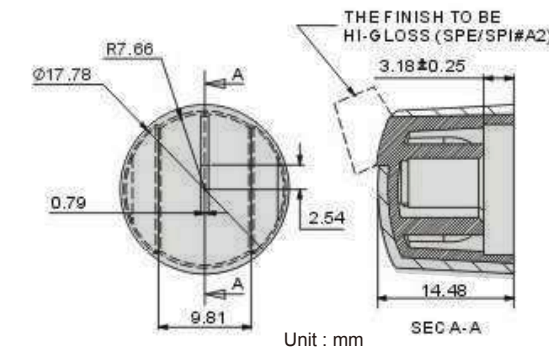

轉鈕

全鋁及鋁殼旋鈕

指示旋鈕

滑鈕

握把旋鈕

控制旋鈕

機械旋鈕

按鍵旋鈕

雙色旋鈕

DIY旋鈕及配件

腳墊

轉鈕

全鋁及鋁殼旋鈕

指示旋鈕

滑鈕

握把旋鈕

控制旋鈕

機械旋鈕

按鍵旋鈕

雙色旋鈕

DIY旋鈕及配件

腳墊



46097 Description

- Material : ABS
- Finish : Glossy
- The knob can glue aluminum skirt K-46097
- This knob needs to fit mating with plastic insert 4192 / 4193

- 材質：ABS
- 表面：亮面
- 此旋鈕可搭配組裝鋁質銘板 K-46097
- 此旋鈕需搭配塑膠塞子4192/ 4193

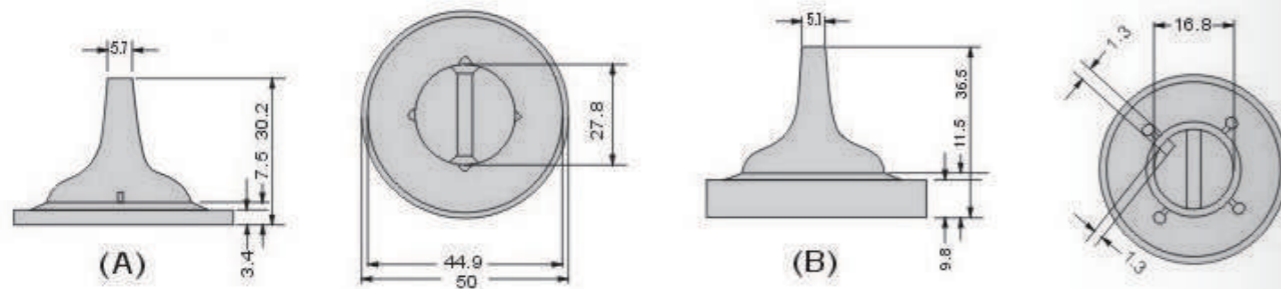

Unit : mm

46099 Description

- Material : ABS
- Finish : Glossy
- The knob can print graphics on skirt surface or glue aluminum skirt K-46097
- This knob needs to fit mating with plastic insert 4192 / 4193

- 材質：ABS
- 表面：亮面
- 此旋鈕可在盤面印刷圖案或搭配組裝鋁質銘板 K-46097
- 此旋鈕需搭配塑膠塞子4192/ 4193

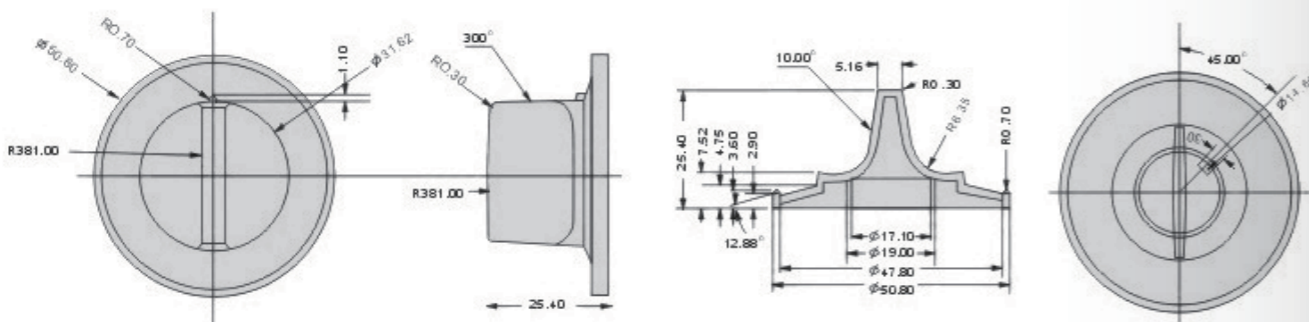

Unit : mm

Plastic insert 塑膠塞子 Description

- Material : Nylon
- Part number 4192 is tall insert
- Part number 4193 is short insert
- Our standard items are as right shown
- All plastic insert are fitted with our knob 46097 / 46099
- If our standard items are not suitable for you, custom design are also available

- 材質：尼龍
- 料號4192為長塑膠塞子
- 料號4193為短塑膠塞子
- 標準品如右圖所示
- 所有塑膠塞子皆可搭配旋鈕46097 / 46099
- 如標準品不適用，歡迎來信洽詢客製品

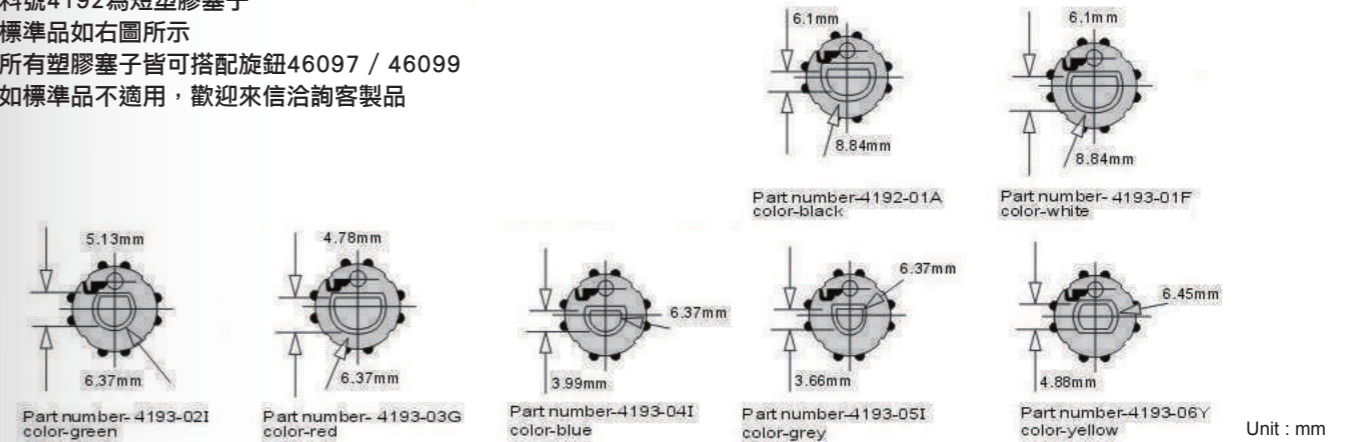

Unit : mm

Aluminum overlay 鋁質銘板 Description

- Material : 0.5 mm thickness aluminum sheet
- Spun aluminum finish with black graphics
- Double side tape on the back of skirt
- All aluminum overlay will fit mating with our knob 46097

- 材質：厚度0.5 mm鋁銘板
- 表面髮線與黑色圖形印刷
- 附背膠
- 所有鋁質銘板皆可搭配旋鈕46097

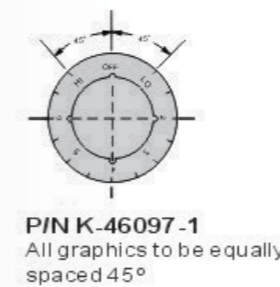

P/N K-46097-4

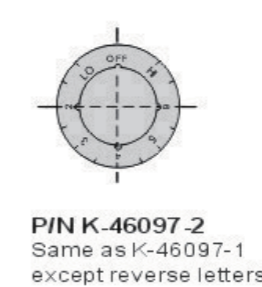

P/N K-46097-5



P/N K-46097-6  
Same as K-46097-3 except reverse letters

Unit : mm

轉鈕

全鋁及鋁殼旋鈕

指示旋鈕

滑鈕

握把旋鈕

控制旋鈕

機械旋鈕

按鍵旋鈕

雙色旋鈕

DIY旋鈕及配件

腳墊

轉鈕

全鋁及鋁殼旋鈕

指示旋鈕

滑鈕

握把旋鈕

控制旋鈕

機械旋鈕

按鍵旋鈕

雙色旋鈕

DIY旋鈕及配件

腳墊

**FT30**
**Description**

- Material : Black ABS
- Finish : Silver or Gold hot stamp on O.D. / TPR on bottom
- Diameter :  $\phi$  30 mm Height : 10.7 mm
- Center hole :  $\phi$  5.1 mm



- 材質：黑色ABS
- 表面：銀或金色熱燙外圈 / 軟膠底
- 外徑： $\phi$  30 mm 高度：10.7 mm
- 中心孔徑： $\phi$  5.1 mm

**FT40**
**Description**

- Material : Black ABS
- Finish : Silver or Gold hot stamp on O.D. / TPR on bottom
- Diameter :  $\phi$  40 mm Height : 13.1 mm
- Center hole :  $\phi$  4.1 mm



- 材質：黑色ABS
- 表面：銀或金色熱燙外圈 / 軟膠底
- 外徑： $\phi$  40 mm 高度：13.1 mm
- 中心孔徑： $\phi$  4.1 mm

**FT55**
**Description**

- Material : Black ABS
- Finish : Silver or Gold hot stamp on O.D. / TPR on bottom
- Diameter :  $\phi$  55 mm Height : 16 mm
- Center hole :  $\phi$  4.1 mm



- 材質：黑色ABS
- 表面：銀或金色熱燙外圈 / 軟膠底
- 外徑： $\phi$  55 mm 高度：16 mm
- 中心孔徑： $\phi$  4.1 mm

**FT-RS28**
**Description**

- Material : Black ABS
- Finish : Silver or Gold hot stamp on O.D. Rubber or Foam on bottom
- Diameter :  $\phi$  28 mm Height : 11.5 mm
- Center hole :  $\phi$  4.2 mm



- 材質：黑色ABS
- 表面：銀或金色熱燙外圈 / 橡膠或泡棉底
- 外徑： $\phi$  28 mm 高度：11.5 mm
- 中心孔徑： $\phi$  4.2 mm

**FT-RS30**
**Description**

- Material : Black ABS
- Finish : Silver or Gold hot stamp on O.D. / Rubber or Foam on bottom
- Diameter :  $\phi$  30 mm Height : 9 mm
- Center hole :  $\phi$  3.2 mm /  $\phi$  3.4 mm

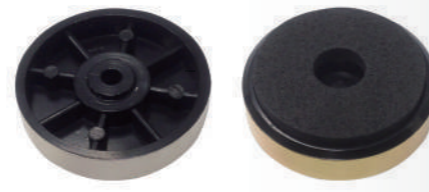

- 材質：黑色ABS
- 表面：銀或金色熱燙外圈 / 橡膠或泡棉底
- 外徑： $\phi$  30 mm 高度：9 mm
- 中心孔徑： $\phi$  4.2 mm /  $\phi$  4.4 mm

**FT-RA35**
**Description**

- Material : Black ABS & Aluminum cap
- Finish : Natural anodized aluminum cap / Rubber or Foam on bottom
- Diameter :  $\phi$  35 mm Height : 11.5 mm
- Center hole :  $\phi$  3.3 mm



- 材質：黑色ABS & 鋁蓋
- 表面：鋁蓋車削銀色陽極處理 / 橡膠或泡棉底
- 外徑： $\phi$  35 mm 高度：11.5 mm
- 中心孔徑： $\phi$  3.3 mm

**FT-RS40**
**Description**

- Material : Black ABS
- Finish : Silver or Gold hot stamp on O.D. / Rubber or Foam on bottom
- Diameter :  $\phi$  40 mm Height : 11 mm
- Center hole :  $\phi$  4.2 mm



- 材質：黑色ABS
- 表面：銀或金色熱燙外圈 / 橡膠或泡棉底
- 外徑： $\phi$  40 mm 高度：11 mm
- 中心孔徑： $\phi$  4.2 mm

**FT-RA40**
**Description**

- Material : Black ABS & Aluminum cap
- Finish : Natural anodized aluminum cap / Rubber or Foam on bottom
- Diameter :  $\phi$  40 mm Height : 12 mm
- Center hole :  $\phi$  4 mm



- 材質：黑色ABS & 鋁蓋
- 表面：鋁蓋車削銀色陽極處理 / 橡膠或泡棉底
- 外徑： $\phi$  40 mm 高度：12 mm
- 中心孔徑： $\phi$  4 mm

**FT-RA45**
**Description**

- Material : Black ABS & Aluminum cap
- Finish : Natural anodized aluminum cap / Rubber or Foam on bottom
- Diameter :  $\phi$  45 mm Height : 12.5 mm
- Center hole :  $\phi$  4.2 mm



- 材質：黑色ABS & 鋁蓋
- 表面：鋁蓋車削銀色陽極處理 / 橡膠或泡棉底
- 外徑： $\phi$  45 mm 高度：12.5 mm
- 中心孔徑： $\phi$  4.2 mm

**FT-RS50**
**Description**

- Material : Black ABS
- Finish : Silver or Gold hot stamp on O.D. / Rubber or Foam on bottom
- Diameter :  $\phi$  50 mm Height : 16.3 mm
- Center hole :  $\phi$  4.3 mm



- 材質：黑色ABS
- 表面：銀或金色熱燙外圈 / 橡膠或泡棉底
- 外徑： $\phi$  50 mm 高度：16.3 mm
- 中心孔徑： $\phi$  4.3 mm